

# YCZ

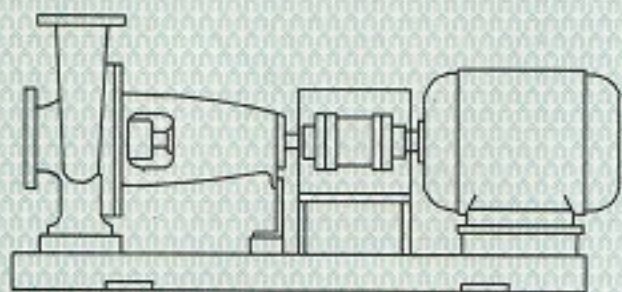

標準化工流程泵

安裝使用說明

STANDARD CHEMICAL  
PROCESS PUMPS  
OPERATING INSTRUCTION

大連寶源科建電力設備制造有限公司

DA LIAN BAO YUAN KE JIAN POWER EQUIPMENT MANUFACTURE CORPORATION

|     |        |
|-----|--------|
| 總覽  | 00-010 |
| 加減器 | 00-020 |
| 齒輪箱 | 10-000 |
| 齒輪  | 00-010 |
| 齒輪箱 | 00-020 |
| 齒輪箱 | 00-030 |
| 齒   | 00-040 |
| 齒   | 10-000 |
| 齒輪箱 | 00-001 |
| 齒輪  | 00-002 |
| 齒輪箱 | 00-003 |
| 齒輪箱 | 00-004 |
| 齒輪箱 | 00-005 |
| 齒輪箱 | 10-001 |
| 齒輪箱 | 00-001 |
| 齒輪  | 00-002 |
| 齒輪  | 00-010 |
| 齒輪  | 00-012 |
| 齒輪箱 | 00-013 |
| 齒輪箱 | 00-014 |
| 齒輪箱 | 00-015 |
| 齒輪箱 | 00-016 |
| 齒輪箱 | 00-017 |
| 齒輪箱 | 00-018 |
| 齒輪箱 | 00-019 |
| 齒輪箱 | 00-020 |
| 齒輪箱 | 00-021 |
| 齒輪箱 | 00-022 |
| 齒輪箱 | 00-023 |
| 齒輪箱 | 00-024 |
| 齒輪箱 | 00-025 |
| 齒輪箱 | 00-026 |
| 齒輪箱 | 00-027 |
| 齒輪箱 | 00-028 |
| 齒輪箱 | 00-029 |
| 齒輪箱 | 00-030 |
| 齒輪箱 | 00-031 |
| 齒輪箱 | 00-032 |
| 齒輪箱 | 00-033 |
| 齒輪箱 | 00-034 |
| 齒輪箱 | 00-035 |
| 齒輪箱 | 00-036 |
| 齒輪箱 | 00-037 |
| 齒輪箱 | 00-038 |
| 齒輪箱 | 00-039 |
| 齒輪箱 | 00-040 |
| 齒輪箱 | 00-041 |
| 齒輪箱 | 00-042 |
| 齒輪箱 | 00-043 |
| 齒輪箱 | 00-044 |
| 齒輪箱 | 00-045 |
| 齒輪箱 | 00-046 |
| 齒輪箱 | 00-047 |
| 齒輪箱 | 00-048 |
| 齒輪箱 | 00-049 |
| 齒輪箱 | 00-050 |
| 齒輪箱 | 00-051 |
| 齒輪箱 | 00-052 |
| 齒輪箱 | 00-053 |
| 齒輪箱 | 00-054 |
| 齒輪箱 | 00-055 |
| 齒輪箱 | 00-056 |
| 齒輪箱 | 00-057 |
| 齒輪箱 | 00-058 |
| 齒輪箱 | 00-059 |
| 齒輪箱 | 00-060 |
| 齒輪箱 | 00-061 |
| 齒輪箱 | 00-062 |
| 齒輪箱 | 00-063 |
| 齒輪箱 | 00-064 |
| 齒輪箱 | 00-065 |
| 齒輪箱 | 00-066 |
| 齒輪箱 | 00-067 |
| 齒輪箱 | 00-068 |
| 齒輪箱 | 00-069 |
| 齒輪箱 | 00-070 |
| 齒輪箱 | 00-071 |
| 齒輪箱 | 00-072 |
| 齒輪箱 | 00-073 |
| 齒輪箱 | 00-074 |
| 齒輪箱 | 00-075 |
| 齒輪箱 | 00-076 |
| 齒輪箱 | 00-077 |
| 齒輪箱 | 00-078 |
| 齒輪箱 | 00-079 |
| 齒輪箱 | 00-080 |
| 齒輪箱 | 00-081 |
| 齒輪箱 | 00-082 |
| 齒輪箱 | 00-083 |
| 齒輪箱 | 00-084 |
| 齒輪箱 | 00-085 |
| 齒輪箱 | 00-086 |
| 齒輪箱 | 00-087 |
| 齒輪箱 | 00-088 |
| 齒輪箱 | 00-089 |
| 齒輪箱 | 00-090 |
| 齒輪箱 | 00-091 |
| 齒輪箱 | 00-092 |
| 齒輪箱 | 00-093 |
| 齒輪箱 | 00-094 |
| 齒輪箱 | 00-095 |
| 齒輪箱 | 00-096 |
| 齒輪箱 | 00-097 |
| 齒輪箱 | 00-098 |
| 齒輪箱 | 00-099 |
| 齒輪箱 | 00-100 |

1. 本說明書適用於...  
 2. 本說明書適用於...  
 3. 本說明書適用於...  
 4. 本說明書適用於...  
 5. 本說明書適用於...

## 目 錄

|          |    |
|----------|----|
| 1、概述     | 2  |
| 2、安裝使用說明 | 2  |
| 3、運行     | 6  |
| 4、維護保養   | 6  |
| 5、檢修     | 9  |
| 附圖       | 10 |
| 附表—1     | 11 |
| 附表—2     | 12 |

## Contents

|   |    |
|---|----|
| 1、Brief of Description                      | 14 |
| 2、Description of Installation and Operation | 14 |
| 3、Running                                   | 19 |
| 4、Maintenance                               | 19 |
| 5、Examination and repair                    | 23 |
| Attached diagram                            | 25 |
| Attached table—1                            | 26 |
| Attached table—2                            | 27 |

## 1、概 述

在對 YCZ 系列產品的安裝使用作以說明之前特別對其安全性作如下概述：

1.1 應保證泵的使用工况點與合同要求的數據或泵的銘牌上所注明的參數相吻合。

1.2 如果在泵停車後能產生有害的回流，必須安裝止回裝置。

1.3 未裝聯軸器罩的泵不得啓動。

1.4 泵在重新組裝後，應將卡盤夾扁，卡住葉輪螺母以防止其鬆動。（見結構圖 1—1）

1.5 泵的進出口法蘭、螺紋孔及其它敞開部位在運輸及存放期間必須封堵。

1.6 不得用泵和電機上的環螺栓起吊泵單機或整個機組

1.7 不得隨意排放所輸送的介質以免腐蝕泵的基礎及污染環境。

1.8 在正式運轉之前，無特殊情況不得自行將泵解體。（不包括爲了安裝泵底座而將電機和聯軸器拆下）

## 2、安裝使用說明

YCZ 系列標準化工流程泵係臥式、單級、單吸懸臂式離心泵。產品符合 DIN24256/ISO2858 標準。適宜輸送清潔的或含有微量顆粒的、中性的或有腐蝕性的、低溫的或高溫的介質。

該泵採用“後拉出”式結構。維修時可不必拆卸進出口管路甚至電機。整個轉子部件（葉輪、軸封組件、軸承支架部件等）可以從後部拉出。（見圖 2—1）

YCZ 系列泵均採用閉式葉輪型式。作用於軸封處的壓力由葉輪的背葉片或平衡孔平衡。

填料箱體（泵蓋）根據使用的具體情況可安裝填料密封或機械密封。在正常使用情況下填料箱體不帶冷卻腔。在特殊情況下，填料箱體可以製成冷卻或加熱結構。

軸承採用稀油潤滑。

可根據用戶的要求配備 API610 輔助管路系統。

2.1 整機的安裝

|          |      |
|----------|------|
| 010.00   | 泵體   |
| 030.00   | 填料函  |
| 030.01   | 填料函  |
| * 040.00 | 葉輪   |
| * 050.00 | 磨損環  |
| * 051.00 | 磨損環  |
| 090.00   | 軸    |
| 090.01   | 軸    |
| 100.00   | 軸承架  |
| 130.00   | 泵蓋   |
| 140.00   | 防酸環  |
| 164.00   | 滾動軸承 |
| 164.01   | 滾動軸承 |
| 164.02   | 滾動軸承 |
| * 306.00 | 軸套   |
| 323.00   | 擋圈   |
| * 326.00 | 卡盤   |
| 335.00   | 壓蓋襯套 |
| 336.00   | 壓蓋法蘭 |
| 340.00   | 軸承壓蓋 |
| 340.01   | 軸承壓蓋 |
| 367.00   | 水封環  |
| 391.00   | 支脚   |
| 430.00   | O 形環 |
| 430.01   | O 形環 |
| 431.00   | 密封環  |
| * 431.01 | 密封環  |
| * 432.00 | 密封墊  |
| * 432.01 | 密封墊  |
| * 440.00 | 填料   |
| * 461.00 | 葉輪螺母 |
| 511.00   | 卡環   |
| 511.01   | 卡環   |
| 540.00   | 排氣油塞 |
| 552.00   | 恆位油杯 |

帶 \* 號者爲易損件

- A 帶付葉片的葉輪，填料函不需冷卻
- B 帶付葉片的葉輪，填料函帶冷卻
- C 帶平衡孔的葉輪，葉輪名義直徑爲 315 毫米，後殼耐磨環 填料函冷卻/不冷卻



图 1-1



圖 2-1

2·1·1 主要尺寸、連接、固定螺栓的位置，螺栓的規格，法蘭執行標準請查閱《CZ 標準化工泵外形尺寸表》。

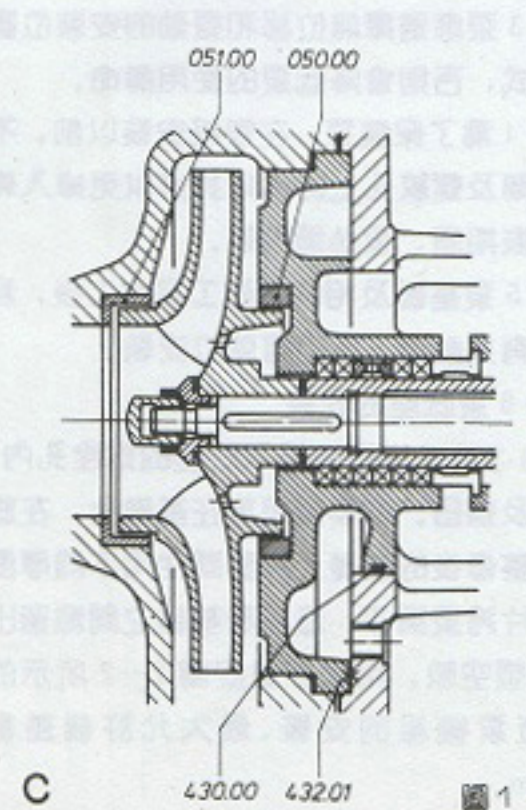
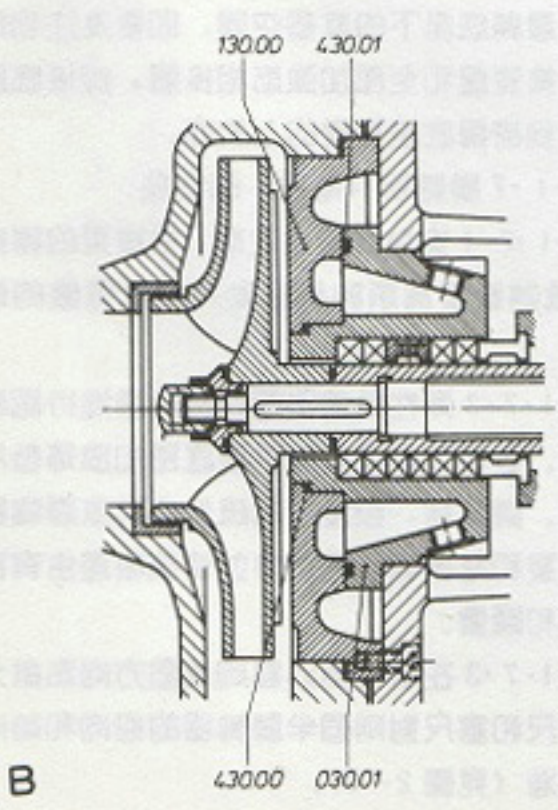
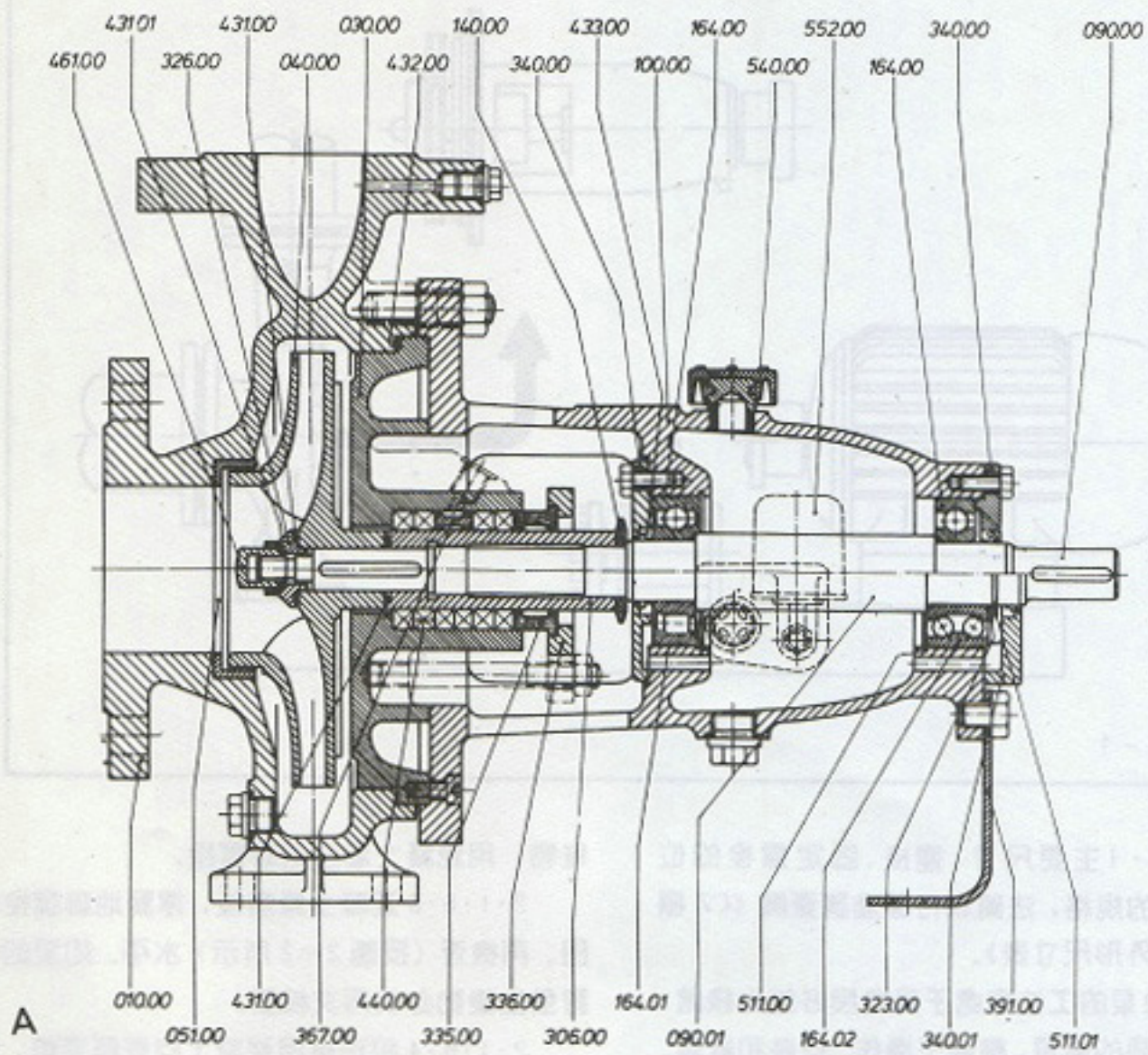
2·1·2 泵的工位應處于具有良好的光綫處，應具有方便的電源，應便于操作、安裝和維修。

2·1·3 泵應選擇無位移和振動的安裝位置和安裝方式，否則會降低泵的使用壽命。

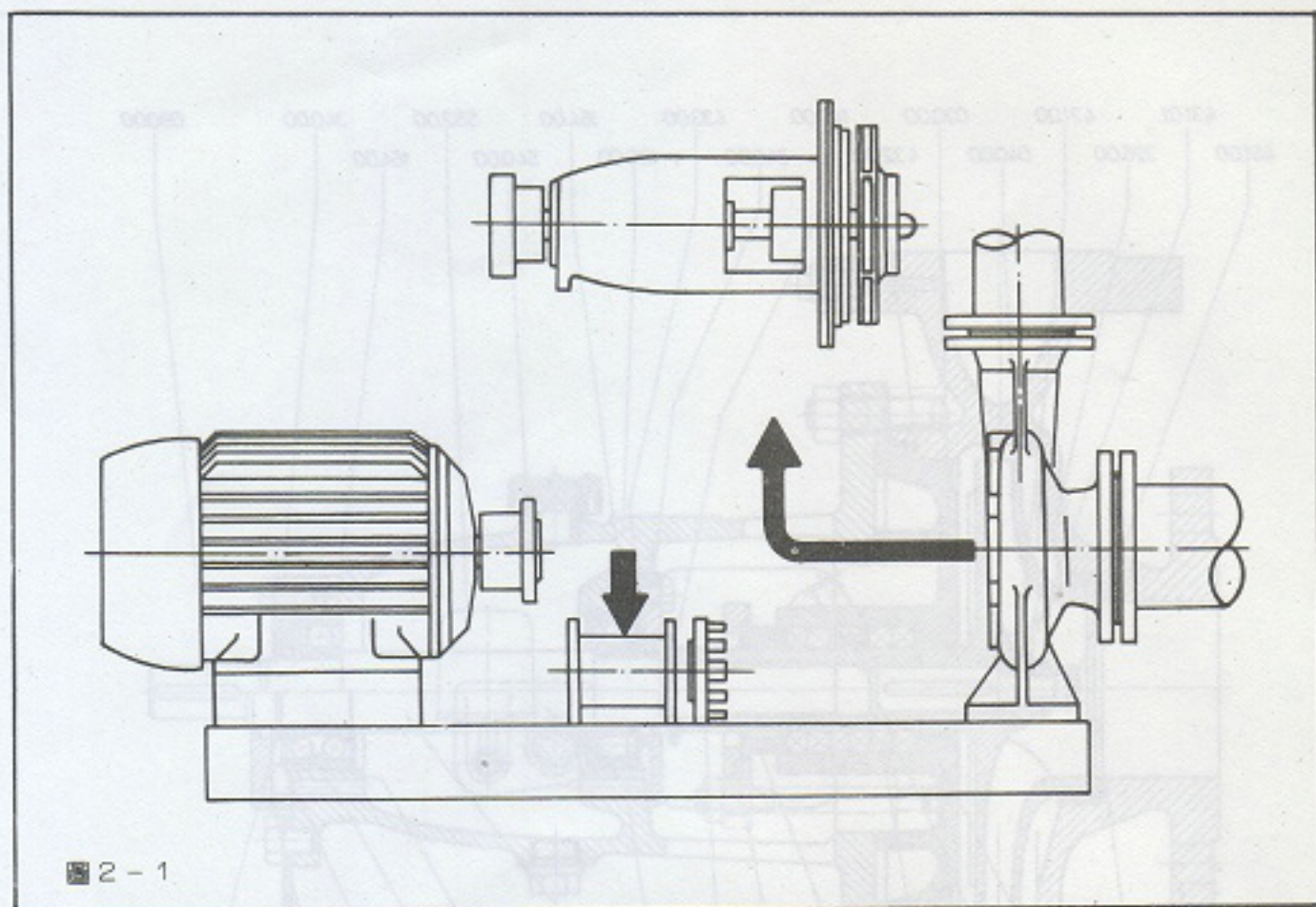
2·1·4 爲了保護泵，在管路安裝以前，不得將泵法蘭及螺紋孔上的孔堵拆掉以免掉入雜物。在安裝期間，泵必須蓋好。

2·1·5 泵基礎及相關土木工程完工後，混凝土達到有效齡期。泵方可就位安裝。

#### 2·1·6 泵底座的安裝

2·1·6·1 將地腳螺栓擰入底座的螺栓孔內，旋上墊圈及螺母。將泵機組放在基礎上，在底座底面和整修後的基礎上表面間使用不同厚度的鋼製墊片將泵調平。底座和基礎之間應留出一定的灌漿空隙。用水平儀按圖 2-2 所示的方法檢查泵機組的安裝。最大允許偏差爲 0.1mm/m。

2·1·6·2 清除地腳螺栓預留孔內的積水和

雜物，用混凝土灌注地腳螺栓。

2·1·6·3 混凝土凝固後，擰緊地腳螺栓螺母。再檢查（按圖 2-2 所示）水平。如泵的位置發生變動必須再次校正。

2·1·6·4 校正後用混凝土向底座灌漿。混凝土應灌滿底座下的整個空間，即要澆注到與頂板、集液盤和全部加強筋相接觸。焊接底座要灌注到槽鋼底座基礎的上表面。

#### 2·1·7 聯軸器（電機）的安裝

2·1·7·1 安裝聯軸器之前，根據泵的轉向（從電機端看泵爲順時針轉動）檢查電機的轉向。

2·1·7·2 彈性聯軸器要對軸心綫進行認真的校准。這項工作可由向電機底部加放薄墊片來完成。請注意，校准時的疏忽會導致聯軸器破壞及泵和電機軸承的損壞並使機組產生有害的振動和噪聲。

2·1·7·3 在聯軸器外圓周幾個方向點處分別用平尺和塞尺對兩個半聯軸器的徑向和軸向進行校准（見圖 2-3）。

2·1·7·4 在泵的轉速大于 3600r/min 並且

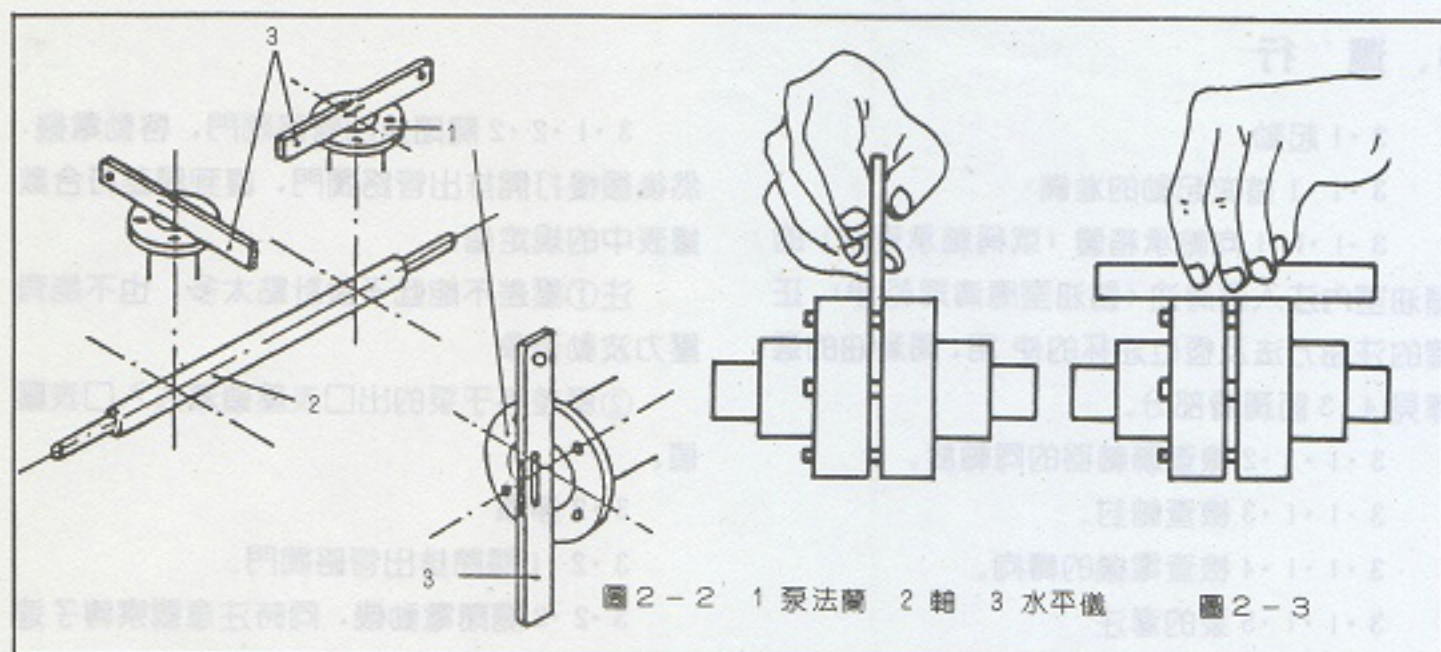

具有加長聯軸器時，需進行更精確的安裝。用千分表按圖 2-4 所示在徑向和軸向進行測量。徑向最大允許軸向誤差為 0.05mm，但盡可能  $\leq 0.03\text{mm}$ 。徑向最大允許徑向誤差為 0.1mm，但盡可能  $\leq 0.05\text{mm}$ 。

2.1.7.5 在使用溫度較高時（130℃以上），如進行 2.1.7.4 項的精確安裝，則必須在使用溫度下校正其安裝精度。

#### 2.2 管路及用于軸封輔助系統的管路接口

##### 2.2.1 管路的安裝

2.2.1.1 盡管泵能夠承受一定的外力和外力矩，也應對管路進行有效的支撐，以避免管路重量和管路熱應力產生的力和力矩超出泵管口所允許的最大外荷載，從而導致泵產生變形。（最大允許管口荷載見附表 1）

2.2.1.2 應保證泵法蘭和配管法蘭間密封墊片的對中，以免管路截面堵塞。

2.2.1.3 應避免采用不規則的管路和較小回轉半徑的彎頭，否則會增大阻力。特別是對於泵的吸入管路，較大的管路阻力會導致泵入口處的壓力降低，影響泵的吸上能力，嚴重的將會導致泵發生汽蝕，不能正常工作。

##### 2.2.2 用于軸封輔助系統的管路接口

2.2.2.1 當在訂貨時按 API 規範或按 GB5656-85 標準指定輔助管路系統時，可根據泵所配帶的管路及管接頭進行連接。

2.2.2.2 當需要根據用戶自己的使用經驗或現場的實際情況安裝輔助管路時，可參考附表 2 進行。

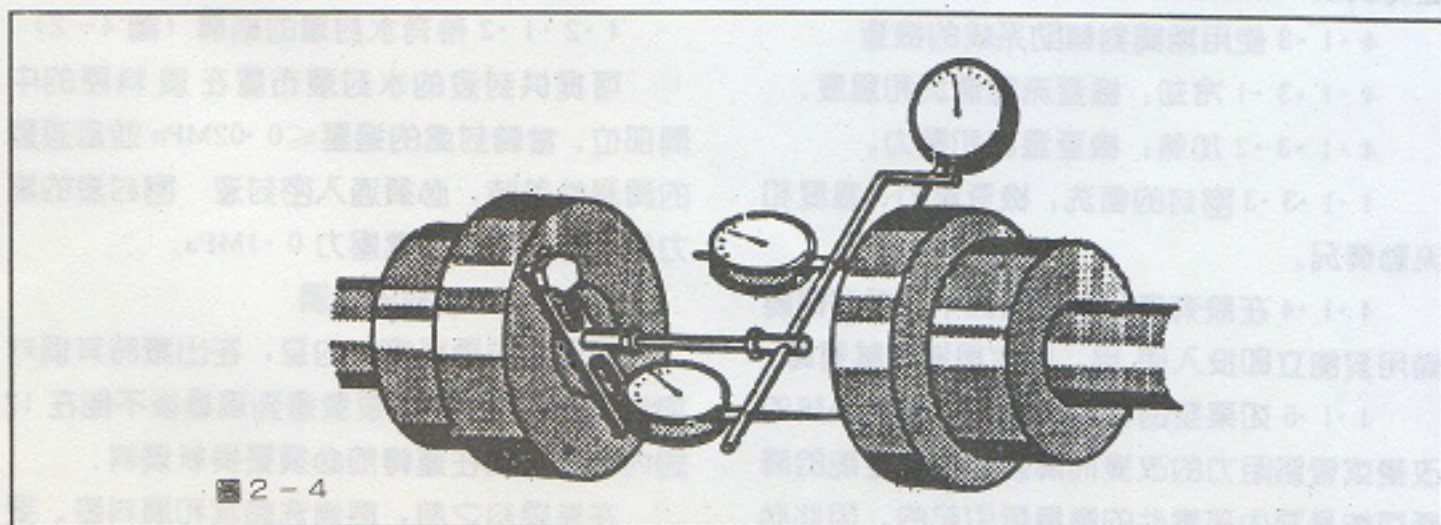

### 3、運 行

#### 3·1 起動

##### 3·1·1 首次起動的準備

3·1·1·1 向軸承箱體（或稱軸承支架）的儲油室內注入潤滑油（儲油室應清理乾淨）正確的注油方法及恆位油杯的使用，潤滑油的選擇見 4·3 節潤滑部分。

##### 3·1·1·2 檢查聯軸器的同軸度。

##### 3·1·1·3 檢查軸封。

##### 3·1·1·4 檢查電機的轉向。

##### 3·1·1·5 泵的灌注

##### 3·1·1·5·1 泵處于倒灌情況

打開吸入管路閥門，在泵的出口管和密封箱體的螺塞處排氣。當無氣泡時關閉排氣塞。

##### 3·1·1·5·2 泵處于吸上情況。

吸入管路必須安裝底閥。打開入口管路閥門，用輸送介質灌泵排氣或用真空泵抽吸。

#### 3·1·2 泵的啟動和運行

##### 3·1·2·1 打開輔助設備管路中的閥門。

3·1·2·2 關閉排出管路閥門，啟動電機。然後緩慢打開排出管路閥門，直到壓差符合數據表中的規定值。

注①壓差不能低于設計點太多，也不能有壓力波動現象

②壓差等于泵的出口表壓值減去入口表壓值。

#### 3·2 停車

##### 3·2·1 關閉排出管路閥門。

3·2·2 關閉電動機。同時注意觀察轉子緩慢停下時的情況。

3·2·3 如果泵在吸上條件下工作，並且在停車後短時間內不打算再開車，此時必須關閉吸入管路閥門。

3·2·4 關閉輔助設備管路中的閥門（冷却水在泵冷却後關閉）。

3·2·5 有凍結現象或在長期停用的情況下，必須排空泵及輔助系統中的液體。

### 4、維護保養

#### 4·1 泵

4·1·1 在運轉期間檢查泵機組運轉的平穩性，觀察有無振動現象。注意異常的運轉噪聲在不知道噪聲和故障產生的原因的情況下，首先應立即停車，查明原因並排除。

4·1·2 經常檢查聯軸器的連接情況。為了避免損壞，發生變形應立即消除。

##### 4·1·3 使用期間對輔助系統的檢查

##### 4·1·3·1 冷却：檢查流動情況和溫度。

##### 4·1·3·2 加熱：檢查溫度和壓力。

4·1·3·3 密封的衝洗：檢查壓力、溫度和流動情況。

4·1·4 在設有備用泵的情況下，為了保證備用泵能立即投入使用，應定期進行試運轉。

4·1·5 如果泵的性能不是因為管路系統的改變或管路阻力的改變而降低，則泵性能的降低可能是泵內部零件的磨損所引起的，因此必

須檢修泵，更換已磨損的零件。

#### 4·2 軸封

##### 4·2·1 填料密封

##### 4·2·1·1 常規結構（圖 4-1）

用填料環填充整個填料腔。軸封處的最小過壓為  $0.01 \sim 0.02 \text{MPa}$ ，介質必須具有一定的潤滑性並且絕對清潔。

##### 4·2·1·2 帶有水封環的結構（圖 4-2）

可提供封液的水封環布置在填料腔的中間部位。當軸封處的過壓  $\leq 0.02 \text{MPa}$  並且液體的潤滑性差時，必須通入密封液。密封液的壓力最小應大于軸封處壓力  $0.1 \text{MPa}$ 。

##### 4·2·1·3 填料的裝填

對於要求填料密封的泵，在出廠時其填料密封已裝填好。如果泵發運到現場後不能在 12 周內啟動，則在運轉前必須更換新填料。

在裝填料之前，應清洗軸套和填料腔。要

檢查軸套表面的行位公差和表面粗糙度。

要求:

①軸套外表面徑向圓跳動不大于  $0.05\text{mm}$ 。

②軸套外表面的粗糙度不低于  $0.8$ 。

裝填料時應將填料環一個一個推入填料腔

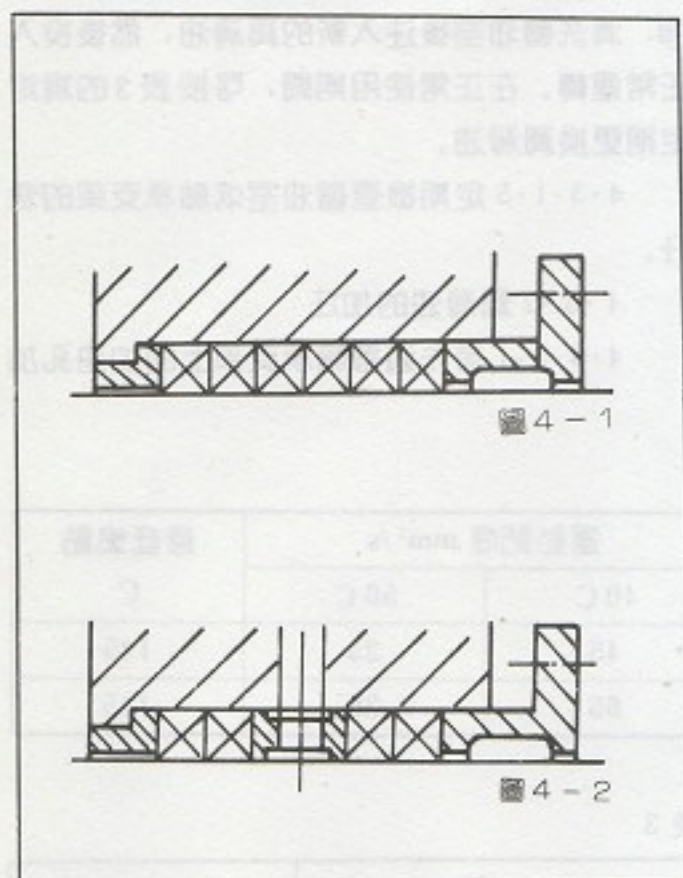

內。每個填料環的接縫處應互相錯開  $90^\circ$  並靠緊。帶水封環的結構應注意將水封環對准封液入口。

在灌泵前均勻壓緊填料，不得壓偏。可用檢測儀器檢查壓蓋法蘭與填料腔的距離。使其保證均勻，然後上緊螺母。

#### 4.2.1.4 監視

填料密封應具有一定的泄漏量以保證良好的潤滑及冷卻效果和運轉的平穩。當泄漏液的溫度不超過  $60^\circ\text{C}$  時，泄漏量從  $1$  升/小時（大約每秒一滴）到  $15$  升/小時（大約直徑為  $2\text{mm}$  的液流）均可視為正常。

一般情況下可按表 1 值控制泄漏量：

當軸封處的壓力小於  $1\text{MPa}$ ，泄漏量超出上述規定時，可均勻壓緊填料，但不要使填料壓蓋偏斜，也不要壓得太緊。如果重新壓緊填料

後泄漏仍較大，並且泄漏液的溫度超出允許值應更換新填料。

當軸封外的壓力大於  $1\text{MPa}$  時，在泵運轉情況下，再次壓緊填料會導致軸封失敗。此時應更換新填料。

每次裝填新填料後都必須經過一段磨合期，在磨合期應注意檢查。磨合期後軸封的泄漏量將會減小。

#### 4.2.2 機械密封

##### 4.2.2.1 單端面機械密封

為了保證具有良好的密封性能和平穩的運轉，在密封的摩擦付（動環和靜環）之間必須保持一個液膜。因此所輸送的介質應滿足下列條件：

表 1

| 泵的設計流量 $\text{m}^3/\text{h}$ | 軸封的泄漏量 $\text{ml}/\text{min}$ |
|------------------------------|-------------------------------|
| $\leq 50$                    | 15                            |
| $> 50-100$                   | 20                            |
| $> 100-300$                  | 30                            |
| $> 300-1000$                 | 40                            |
| $> 1000$                     | 60                            |

①良好的潤滑性。

②汽化溫度大於工作溫度。

③摩擦付附近介質不含雜質和顆粒。

單端面機械密封的維護主要包括對輔助系統、泄漏量和機械密封腔體溫度的監控。一般情況下，當單端面機械密封的泄漏量不超過  $10\text{ml}/\text{h}$  時，可視為正常。當泄漏量較大（大於  $50\text{ml}/\text{h}$ ）時，可以斷定密封已損壞，應立即檢修。檢修時應對磨損的密封面重新研磨拋光。對不能經研磨修復的密封環，應予更換。

在每次拆裝密封時，靜密封件（如 O 型圈等）必須更換。

##### 4.2.2.2 雙端面機械密封

在兩個端面密封所形成的空腔內必須通入密封液。封液的壓力要高於輸送介質端軸封處壓力的  $0.05\sim 0.1\text{MPa}$ 。

雙端面機械密封的維護主要包括封液的填



充、密封和輔助系統的速度控制

當封環損耗較大或軸封處漏量較大時，可以斷定密封件已損壞，應立即檢修。檢修時應對磨損的密封面重新研磨拋光，對不能研磨修復的密封環應予更換。在每次拆裝密封時，靜密封件（如 O 型圈等）必須換新。

#### 4.3 潤滑

##### 4.3.1 潤滑油

4.3.1.1 為了保證軸承有一個較長的使用壽命並能無故障運轉，良好的潤滑是一個必要的條件

4.3.1.2 潤滑油不能含有任何雜質、酸或樹脂等

4.3.1.3 軸承在運轉過程中發熱及環境溫

度的升高對潤滑油的粘度變化起重要作用。粘度的變化將直接影響其潤滑性。為了保證軸承具有良好的潤滑條件，要求在軸承的使用溫度範圍內潤滑油的運動粘度不得低於  $12\text{mm}^2/\text{s}$ 。可按表 2 提供的數據選擇潤滑油。

4.3.1.4 在首次使用或軸承檢修後重新使用的情况下，當運轉 10—15 小時後應將油排淨，清洗儲油室後注入新的潤滑油，然後投入正常運轉。在正常使用期間，可按表 3 的規定定期更換潤滑油。

4.3.1.5 定期檢查儲油室或軸承支架的溫升。

##### 4.3.2 潤滑油的加注

4.3.2.1 首先通過軸承支架上的加油孔加

表 2

| 溫 度 C |        | ISO<br>粘度等級 | 運動粘度 $\text{mm}^2/\text{s}$ |      | 最低燃點<br>C |
|-------|--------|-------------|-----------------------------|------|-----------|
| 儲油室   | 軸承支架   |             | 40 C                        | 50 C |           |
| 40~65 | >50~75 | VG46        | 45                          | 25   | 145       |
| 65~75 | >75~85 | VG68        | 65                          | 36   | 145       |

注潤滑油，油加到櫃位油杯的支管內見到油或加注到儲油室的示油窗上的指示線為止。

4.3.2.2 按圖 4-3 所示，向櫃位油杯加油，然後將油杯恢復到工作位置（圖 4-4）。如果油杯在工作位置時，油杯內的油量不足油杯

表 3

| 溫 度 C  |        | 更換週期(月) |
|--------|--------|---------|
| 儲油室    | 軸承支架   |         |
| >40~65 | >50~75 | 12      |
| >65~75 | >75~80 | 6       |

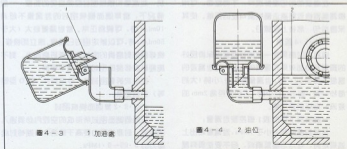

容量的2/3,可重複上述過程,直至油杯內有2/3的油量為止。

4.3.2.3 使用一段時間後,軸承支架儲油

## 5、檢 修

為避免過長的停車檢修期,應提前採購好必要的備品備件。在向製造廠購買備件時,應向製造廠提供泵型號,軸封型式及所需零部件的確切規格等有關資料,以便製造廠檢索。

### 5.1 拆卸

#### 5.1.1 準備工作

5.1.1.1 關閉泵的進出口閥門並注意不得隨意打開以免造成事故。

5.1.1.2 切斷電機電源以防止電機突然起動。

5.1.1.3 排淨泵內液體及潤滑油。

5.1.1.4 拆除聯軸器罩,拆開聯軸器或拆下電機

5.1.1.5 拆掉所有的儀表及輔助管路。

#### 5.1.2 拆卸組件

5.1.2.1 拆掉軸承支架的支腳螺栓。

5.1.2.2 拆掉泵體雙頭螺柱的螺母。

5.1.2.3 卸下組件(帶有軸的軸承支架,泵蓋、葉輪等組合在一起),對於較大的泵,可借助於軸承支架上的吊環螺釘進行組件的拆卸。

#### 5.1.3 軸封的拆卸

5.1.3.1 固定泵軸,撬開卡盤,拆掉葉輪螺母。

5.1.3.2 拆下葉輪。

室內的油位下降,則重複4.3.2.2的過程,直至達到要求為止。

5.1.3.3 拆掉泵蓋定位螺釘,卸下泵蓋。

5.1.3.4 拆下機械密封壓蓋或填料壓蓋法蘭的緊固件。

5.1.3.5 對於機械密封,應將軸套和密封轉動件一起抽出。

#### 5.1.4 泵軸的拆卸

5.1.4.1 拆下軸套。

5.1.4.2 拆下泵端聯軸器。

5.1.4.3 拆下防塵盤(折流盤)。

5.1.4.4 拆掉前後軸承壓蓋。

5.1.4.5 用木錘從驅動端將軸敲出。

#### 5.2 零件檢查

檢查零件的磨損情況,對損壞的零件應重新修復或更換。

#### 5.2.1 葉輪及轉動間隙

5.2.1.1 檢查葉輪的磨蝕和腐蝕情況,損壞嚴重的應予更換。

5.2.1.2 檢查葉輪與泵體及泵蓋耐磨環(又稱口環)的間隙。如間隙超出了表4的規定,可按表4的值進行修復或更換新件。

#### 5.2.2 軸封部件

##### 5.2.2.1 機械密封

動密封和靜密封的磨擦表面必須無任何劃痕,如果有劃痕需要重新研磨拋光或將其更換之。

表 4

| 葉輪與泵體(泵蓋)耐磨環間隙處的直徑(mm) |     | <75 | 75~140 | >140~200 | >200~320 | >320~400 |
|------------------------|-----|-----|--------|----------|----------|----------|
| 新零件的間隙值<br>(mm)        | 鑄鐵  | 0.3 | 0.4    | 0.5      | 0.6      | 0.7      |
|                        | 不銹鋼 | 0.5 | 0.6    | 0.7      | 0.8      | 0.9      |
| 舊零件的間隙值<br>(mm)        | 鑄鐵  | 0.9 | 1.2    | 1.5      | 1.8      | 2.0      |
|                        | 不銹鋼 | 1.5 | 1.8    | 2.0      | 2.5      | 2.8      |

### 5.2.2.2 填料密封

5.2.2.2.1 對於已磨損有溝痕的軸套表面，如果重新加工修復後其直徑與原有直徑相差不足 1mm 則可使用。在軸封壓力大于 1MPa 的情況下，必須更換新軸套。

5.2.2.2.2 按表 5 檢查填料壓蓋襯套與軸套之間的間隙。

### 5.2.3 軸承

清洗軸承並加以檢查，如有損壞則更換

### 5.3 重新組裝

表 5

| 軸封壓力  |     | ≤ 1MPa | > 1MPa |
|-------|-----|--------|--------|
| 間隙 mm | 標準值 | 1mm    | 0.6mm  |
|       | 最大值 | 2mm    | 1.2mm  |

### 5.3.1 準備工作

5.3.1.1 清洗所有泵零部件。

5.3.1.2 準備好潤滑劑（如潤滑油、二硫化鉬等）。

### 5.3.2 軸及軸承的裝配

5.3.2.1 將軸承加熱到 80℃ 左右（浸入熱油內）然後將其裝在軸上。

5.3.2.2 將帶有軸承的泵軸從聯軸器端插入軸承支架內。將軸承壓蓋密封面塗上環氧膠後，裝在軸承支架上。

5.3.2.3 裝上防塵盤。

5.3.2.4 裝上泵聯軸器。

### 5.3.3 整機的組裝

按拆卸的反順序將清洗後的零部件組裝成整機

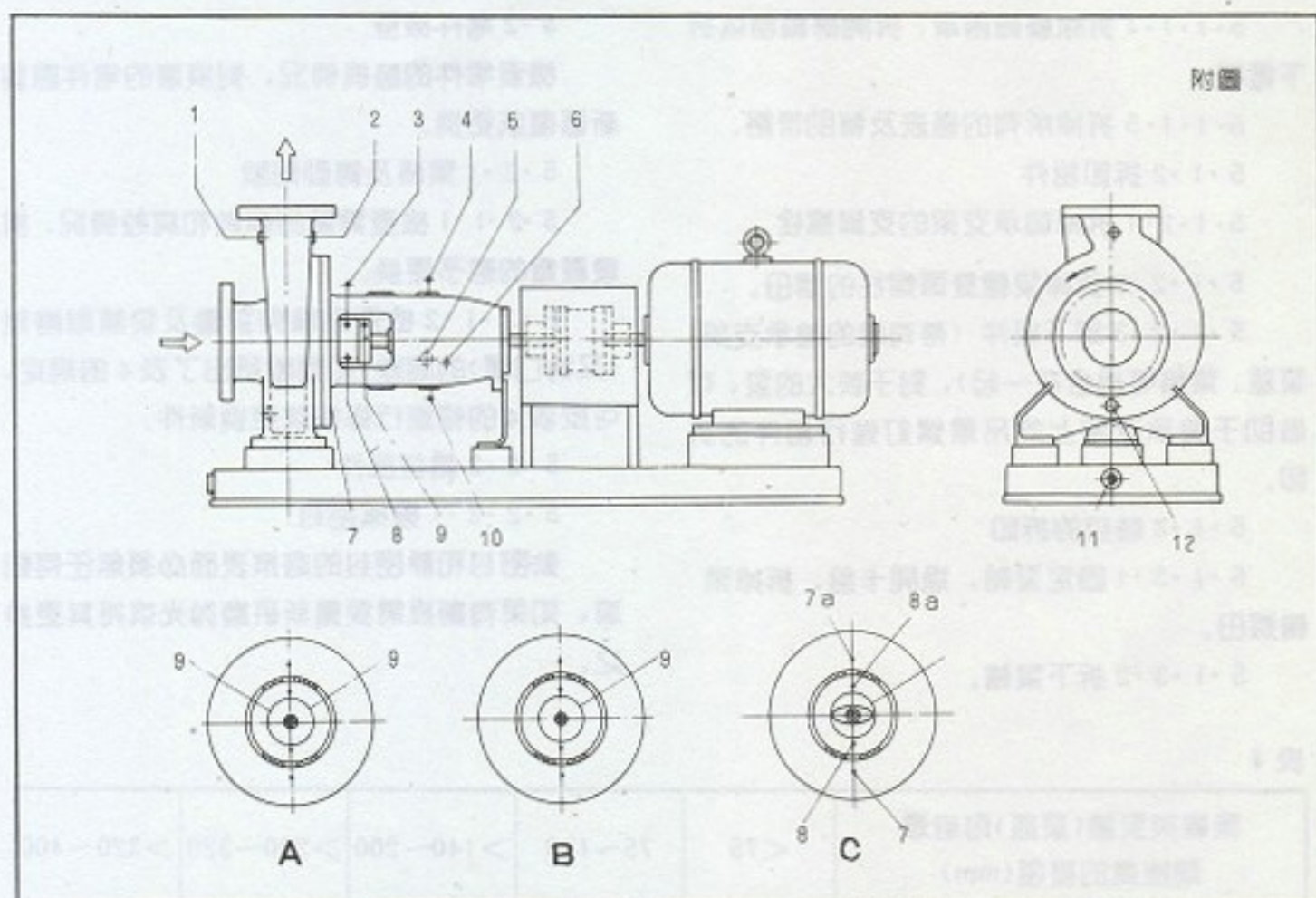

- A 雙端面機械密封
- B 單端面機械密封
- C 填料密封

附表 1

| 接<br>規<br>格 | 代 號  |      |      |      |      |      |      |      |      |      |      |      |    |      |    |
|-------------|------|------|------|------|------|------|------|------|------|------|------|------|----|------|----|
|             | 1    | 2    | 3    | 4    | 5    | 6    | 7    | 7a   | 8    | 8a   | 9    | 10   | 11 | 12   | 13 |
| 32—160      | G1/4 | G1/4 | G1/4 | G1/2 | G1/2 | G1/4 |      |      | G3/8 | G3/8 | G1/4 | G1/2 | G1 | G1/4 |    |
| 32—200      | G1/4 | G1/4 | G1/4 | G1/2 | G1/2 | G1/4 |      |      | G3/8 | G3/8 | G1/4 | G1/2 | G1 | G1/4 |    |
| 32—250      | G1/2 | G1/2 | G1/4 | G1/2 | G1/2 | G1/4 |      |      | G3/8 | G3/8 | G1/4 | G1/2 | G1 | G1/2 |    |
| 40—160      | G1/4 | G1/4 | G1/4 | G1/2 | G1/2 | G1/4 |      |      | G3/8 | G3/8 | G1/4 | G1/2 | G1 | G1/4 |    |
| 40—200      | G1/4 | G1/4 | G1/4 | G1/2 | G1/2 | G1/4 |      |      | G3/8 | G3/8 | G1/4 | G1/2 | G1 | G1/4 |    |
| 40—250      | G1/2 | G1/2 | G1/4 | G1/2 | G1/2 | G1/4 |      |      | G3/8 | G3/8 | G1/4 | G1/2 | G1 | G1/2 |    |
| 40—315      | G1/2 | G1/2 | G1/4 | G1/2 | G1/2 | G1/4 | G3/8 | G3/8 |      |      | G1/4 | G1/2 | G1 | G1/2 |    |
| 50—160      | G1/4 | G1/4 | G1/4 | G1/2 | G1/2 | G1/4 |      |      | G3/8 | G3/8 | G1/4 | G1/2 | G1 | G1/4 |    |
| 50—200      | G1/4 | G1/4 | G1/4 | G1/2 | G1/2 | G1/4 |      |      | G3/8 | G3/8 | G1/4 | G1/2 | G1 | G1/4 |    |
| 50—250      | G1/2 | G1/2 | G1/4 | G1/2 | G1/2 | G1/4 |      |      | G3/8 | G3/8 | G1/4 | G1/2 | G1 | G1/2 |    |
| 50—315      | G1/2 | G1/2 | G1/4 | G1/2 | G1/2 | G1/4 | G3/8 | G3/8 |      |      | G1/4 | G1/2 | G1 | G1/2 |    |
| 65—160      | G1/2 | G1/2 | G1/4 | G1/2 | G1/2 | G1/4 |      |      | G3/8 | G3/8 | G1/4 | G1/2 | G1 | G1/2 |    |
| 65—200      | G1/2 | G1/2 | G1/4 | G1/2 | G1/2 | G1/4 |      |      | G3/8 | G3/8 | G1/4 | G1/2 | G1 | G1/2 |    |
| 65—250      | G1/2 | G1/2 | G1/4 | G1/2 | G1/2 | G1/4 |      |      | G3/8 | G3/8 | G1/4 | G1/2 | G1 | G1/2 |    |
| 65—315      | G1/2 | G1/2 | G1/4 | G1/2 | G1/2 | G1/4 |      |      | G3/8 | G3/8 | G1/2 | G1/2 | G1 | G1/2 |    |
| 80—160      | G1/2 | G1/2 | G1/4 | G1/2 | G1/2 | G1/4 |      |      | G3/8 | G3/8 | G1/4 | G1/2 | G1 | G1/2 |    |
| 80—200      | G1/2 | G1/2 | G1/4 | G1/2 | G1/2 | G1/4 |      |      | G3/8 | G3/8 | G1/4 | G1/2 | G1 | G1/2 |    |
| 80—250      | G1/2 | G1/2 | G1/4 | G1/2 | G1/2 | G1/4 |      |      | G3/8 | G3/8 | G1/4 | G1/2 | G1 | G1/2 |    |
| 80—315      | G1/2 | G1/2 | G1/4 | G1/2 | G1/2 | G1/4 | G3/8 | G3/8 |      |      | G1/2 | G1/2 | G1 | G1/2 |    |
| 80—400      | G1/2 | G1/2 | G1/4 | G1/2 | G1/2 | G1/4 | G3/8 | G3/8 |      |      | G1/2 | G1/2 | G1 | G1/2 |    |
| 100—200     | G1/2 | G1/2 | G1/4 | G1/2 | G1/2 | G1/4 |      |      | G3/8 | G3/8 | G1/4 | G1/2 | G1 | G1/2 |    |
| 100—250     | G1/2 | G1/2 | G1/4 | G1/2 | G1/2 | G1/4 |      |      | G3/8 | G3/8 | G1/2 | G1/2 | G1 | G1/2 |    |
| 100—315     | G1/2 | G1/2 | G1/4 | G1/2 | G1/2 | G1/4 | G3/8 | G3/8 |      |      | G1/2 | G1/2 | G1 | G1/2 |    |
| 100—400     | G1/2 | G1/2 | G1/4 | G1/2 | G1/2 | G1/4 | G3/8 | G3/8 |      |      | G1/2 | G1/2 | G1 | G1/2 |    |
| 125—250     | G1/2 | G1/2 | G1/4 | G1/2 | G1/2 | G1/4 |      |      | G3/8 | G3/8 | G1/2 | G1/2 | G1 | G1/2 |    |
| 125—315     | G1/2 | G1/2 | G1/4 | G1/2 | G1/2 | G1/4 | G3/8 | G3/8 |      |      | G1/2 | G1/2 | G1 | G1/2 |    |
| 125—400     | G1/2 | G1/2 | G1/4 | G1/2 | G1/2 | G1/4 | G3/8 | G3/8 |      |      | G1/2 | G1/2 | G1 | G1/2 |    |
| 150—250     | G1/2 | G1/2 | G1/4 | G1/2 | G1/2 | G1/4 |      |      | G3/8 | G3/8 | G1/2 | G1/2 | G1 | G1/2 |    |
| 150—315     | G1/2 | G1/2 | G1/4 | G1/2 | G1/2 | G1/4 | G1/2 | G1/2 |      |      | G1/2 | G1/2 | G1 | G1/2 |    |
| 150—400     | G1/2 | G1/2 | G1/4 | G1/2 | G1/2 | G1/4 | G1/2 | G1/2 |      |      | G1/2 | G1/2 | G1 | G1/2 |    |
| 150—500     | G1/2 | G1/2 | G1/4 | G1/2 | G1/2 | G1/4 | G1/2 | G1/2 |      |      | G1/2 | G1/2 | G1 | G1/2 |    |
| 200—250     | G1/2 | G1/2 | G1/4 | G1/2 | G1/2 | G1/4 |      |      | G3/8 | G3/8 | G1/2 | G1/2 | G1 | G1/2 |    |
| 200—315     | G1/2 | G1/2 | G1/4 | G1/2 | G1/2 | G1/4 | G1/2 | G1/2 |      |      | G1/2 | G1/2 | G1 | G1/2 |    |
| 200—400     | G1/2 | G1/2 | G1/4 | G1/2 | G1/2 | G1/4 | G1/2 | G1/2 |      |      | G1/2 | G1/2 | G1 | G1/2 |    |
| 200—500     | G1/2 | G1/2 | G1/4 | G1/2 | G1/2 | G1/4 | G1/2 | G1/2 |      |      | G1/2 | G1/2 | G1 | G1/2 |    |
| 250—315     | G1/2 | G1/2 | G1/4 | G1/2 | G1/2 | G1/4 | G1/2 | G1/2 |      |      | G1/2 | G1/2 | G1 | G1/2 |    |
| 250—400     | G1/2 | G1/2 | G1/4 | G1/2 | G1/2 | G1/4 | G1/2 | G1/2 |      |      | G1/2 | G1/2 | G1 | G1/2 |    |
| 250—500     | G1/2 | G1/2 | G1/4 | G1/2 | G1/2 | G1/4 | G1/2 | G1/2 |      |      | G1/2 | G1/2 | G1 | G1/2 |    |
| 300—400     | G1/2 | G1/2 | G1/4 | G1/2 | G1/2 | G1/4 | G1/2 | G1/2 |      |      | G1/2 | G1/2 | G1 | G1/2 |    |
| 300—500     | G1/2 | G1/2 | G1/4 | G1/2 | G1/2 | G1/4 | G1/2 | G1/2 |      |      | G1/2 | G1/2 | G1 | G1   |    |

注:

1 壓力表接□

2 自衝洗管路系統接□

3 原料箱體(泵蓋)封液接□

4 注油孔

5 視油窗接□

6 恆位油杯接□

7 冷却液入□(蒸汽出□)

7a 冷却液出□(蒸汽入□)

8 冷却液入□(蒸汽出□)

8a 冷却液出□(蒸汽入□)

9 機械密封管路接□

10 排油孔

11 底座集液盤排液□

12 泵體排液□

附表 2

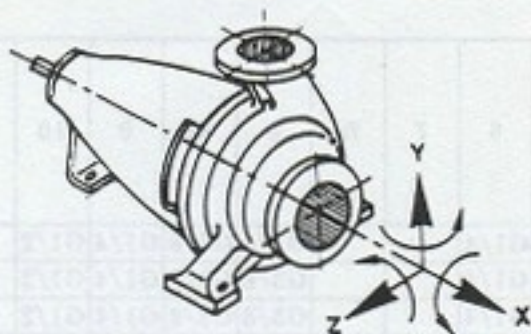

| 泵规格    | 排出口法兰 |            |            |                    |            |           | 吸入口法兰     |     |            |            |            |            |           |           |
|--------|-------|------------|------------|--------------------|------------|-----------|-----------|-----|------------|------------|------------|------------|-----------|-----------|
|        | DN    | 力 [N]      |            |                    | 力距 [Nm]    |           |           | DN  | 力 [N]      |            |            | 力距 [Nm]    |           |           |
|        | mm    | $F_x$      | $F_z$      | $F_y$              | $M_x$      | $M_z$     | $M_y$     | mm  | $F_x$      | $F_z$      | $F_y$      | $M_x$      | $M_z$     | $M_y$     |
| 32-160 | 32    | $\pm 800$  | $\pm 1350$ | $+1750$<br>$-2600$ | $\pm 980$  | $\pm 490$ | $\pm 490$ | 50  | $\pm 800$  | $\pm 1350$ | $\pm 1750$ | $\pm 980$  | $\pm 490$ | $\pm 490$ |
| 32-200 | 32    | $\pm 850$  | $\pm 1420$ | $+1820$<br>$-2750$ | $\pm 1020$ | $\pm 510$ | $\pm 510$ | 50  | $\pm 850$  | $\pm 1420$ | $\pm 1820$ | $\pm 1020$ | $\pm 510$ | $\pm 510$ |
| 32-250 | 32    | $\pm 900$  | $\pm 1500$ | $+1900$<br>$-2900$ | $\pm 1040$ | $\pm 520$ | 520       | 50  | $\pm 900$  | $\pm 1500$ | $\pm 1900$ | $\pm 1040$ | $\pm 520$ | $\pm 520$ |
| 40-160 | 40    | $\pm 850$  | $\pm 1400$ | $+1800$<br>$-2700$ | $\pm 1000$ | $\pm 500$ | $\pm 500$ | 65  | $\pm 850$  | $\pm 1400$ | $\pm 1800$ | $\pm 1000$ | $\pm 500$ | $\pm 500$ |
| 40-200 | 40    | $\pm 900$  | $\pm 1520$ | $+1920$<br>$-2900$ | $\pm 1020$ | $\pm 510$ | $\pm 510$ | 65  | $\pm 900$  | $\pm 1520$ | $\pm 1920$ | $\pm 1020$ | $\pm 510$ | $\pm 510$ |
| 40-250 | 40    | $\pm 950$  | $\pm 1600$ | $+1950$<br>$-2940$ | $\pm 1040$ | $\pm 520$ | $\pm 520$ | 65  | $\pm 950$  | $\pm 1600$ | $\pm 1950$ | $\pm 1040$ | $\pm 520$ | $\pm 520$ |
| 40-315 | 40    | $\pm 980$  | $\pm 1650$ | $+2000$<br>$-3000$ | $\pm 1080$ | $\pm 540$ | $\pm 540$ | 65  | $\pm 980$  | $\pm 1650$ | $\pm 2000$ | $\pm 1080$ | $\pm 540$ | $\pm 540$ |
| 50-160 | 50    | $\pm 900$  | $\pm 1700$ | $+2100$<br>$-3150$ | $\pm 1280$ | $\pm 640$ | $\pm 640$ | 80  | $\pm 900$  | $\pm 1700$ | $\pm 2100$ | $\pm 1280$ | $\pm 640$ | $\pm 640$ |
| 50-200 | 50    | $\pm 950$  | $\pm 1750$ | $+2150$<br>$-3220$ | $\pm 1300$ | $\pm 650$ | $\pm 650$ | 80  | $\pm 950$  | $\pm 1750$ | $\pm 2150$ | $\pm 1300$ | $\pm 650$ | $\pm 650$ |
| 50-250 | 50    | $\pm 1000$ | $\pm 1850$ | $+2250$<br>$-3380$ | $\pm 1320$ | $\pm 660$ | $\pm 660$ | 80  | $\pm 1000$ | $\pm 1850$ | $\pm 2250$ | $\pm 1320$ | $\pm 660$ | $\pm 660$ |
| 50-315 | 50    | $\pm 1100$ | $\pm 1950$ | $+2400$<br>$-3600$ | $\pm 1360$ | $\pm 680$ | $\pm 680$ | 80  | $\pm 1100$ | $\pm 1950$ | $\pm 2400$ | $\pm 1360$ | $\pm 680$ | $\pm 680$ |
| 65-160 | 65    | $\pm 1200$ | $\pm 2150$ | $+2700$<br>$-4000$ | $\pm 1660$ | $\pm 830$ | $\pm 830$ | 100 | $\pm 1200$ | $\pm 2150$ | $\pm 2700$ | $\pm 1660$ | $\pm 830$ | $\pm 830$ |
| 65-200 | 65    | $\pm 1300$ | $\pm 2200$ | $+2800$<br>$-4200$ | $\pm 1680$ | $\pm 840$ | $\pm 840$ | 100 | $\pm 1300$ | $\pm 2200$ | $\pm 2800$ | $\pm 1680$ | $\pm 840$ | $\pm 840$ |
| 65-250 | 65    | $\pm 1400$ | $\pm 2250$ | $+3000$<br>$-4350$ | $\pm 1700$ | $\pm 850$ | $\pm 850$ | 100 | $\pm 1400$ | $\pm 2250$ | $\pm 2900$ | $\pm 1700$ | $\pm 850$ | $\pm 850$ |
| 65-315 | 65    | $\pm 1450$ | $\pm 2350$ | $+3000$<br>$-4500$ | $\pm 1720$ | $\pm 860$ | $\pm 860$ | 100 | $\pm 1450$ | $\pm 2350$ | $\pm 3000$ | $\pm 1720$ | $\pm 860$ | $\pm 860$ |
| 80-160 | 80    | $\pm 1250$ | $\pm 2350$ | $+3000$<br>$-4500$ | $\pm 1850$ | $\pm 910$ | $\pm 910$ | 125 | $\pm 1250$ | $\pm 2350$ | $\pm 3000$ | $\pm 1850$ | $\pm 910$ | $\pm 910$ |
| 80-200 | 80    | $\pm 1300$ | 2400       | $+3100$<br>$-4650$ | $\pm 1840$ | $\pm 920$ | $\pm 920$ | 125 | $\pm 1300$ | $\pm 2400$ | $\pm 3100$ | $\pm 1840$ | $\pm 920$ | $\pm 920$ |
| 80-250 | 80    | $\pm 1400$ | $\pm 2600$ | $+3200$<br>$-4800$ | $\pm 1900$ | $\pm 950$ | $\pm 950$ | 125 | $\pm 1400$ | $\pm 2600$ | $\pm 3200$ | $\pm 1900$ | $\pm 950$ | $\pm 950$ |
| 80-315 | 80    | $\pm 1450$ | $\pm 2700$ | $+3250$<br>$-4850$ | $\pm 1920$ | $\pm 960$ | $\pm 960$ | 125 | $\pm 1450$ | $\pm 2700$ | $\pm 3250$ | $\pm 1920$ | $\pm 960$ | $\pm 960$ |
| 80-400 | 80    | $\pm 1500$ | $\pm 2750$ | $+3300$<br>$-4950$ | $\pm 1940$ | $\pm 970$ | $\pm 970$ | 125 | $\pm 1500$ | $\pm 2750$ | $\pm 3300$ | $\pm 1940$ | $\pm 970$ | $\pm 970$ |

| 泵規格     | 排出口法蘭 |       |       |                  |       |       |       | 吸入口法蘭 |       |       |                  |       |       |       |
|---------|-------|-------|-------|------------------|-------|-------|-------|-------|-------|-------|------------------|-------|-------|-------|
|         | DN    | 力     |       |                  | 力距    |       |       | DN    | 力     |       |                  | 力距    |       |       |
|         | mm    | $F_x$ | $F_z$ | $F_y$            | $M_x$ | $M_z$ | $M_y$ | mm    | $F_x$ | $F_z$ | $F_y$            | $M_x$ | $M_z$ | $M_y$ |
| 100-200 | 100   | ±1500 | ±2600 | +3400<br>-4750   | ±2200 | ±1100 | ±1100 | 125   | ±1500 | ±2600 | ±3400            | ±2200 | ±1100 | ±1100 |
| 100-250 | 100   | ±1650 | ±2700 | +3500<br>-4900   | ±2240 | ±1120 | ±1120 | 125   | ±1650 | ±2700 | ±3500            | ±2240 | ±1120 | ±1120 |
| 100-315 | 100   | ±1700 | ±2750 | +3600<br>-5050   | ±2260 | ±1130 | ±1130 | 125   | ±1700 | ±2750 | ±3600            | ±2260 | ±1130 | ±1130 |
| 100-400 | 100   | ±1800 | ±2850 | +3700<br>-5180   | ±2280 | ±1140 | ±1140 | 125   | ±1800 | ±2850 | ±3700            | ±2280 | ±1140 | ±1140 |
| 125-250 | 125   | ±1800 | ±3500 | +4500<br>-6200   | ±2800 | ±1400 | ±1400 | 150   | ±1800 | ±3500 | ±4500            | ±2800 | ±1400 | ±1400 |
| 125-315 | 125   | ±2000 | ±3600 | +4650<br>-6400   | ±2860 | ±1430 | ±1430 | 150   | ±2000 | ±3600 | ±4650            | ±2860 | ±1430 | ±1430 |
| 125-400 | 125   | ±2100 | ±3650 | +4700<br>-6500   | ±2880 | ±1400 | ±1440 | 150   | ±2100 | ±3650 | ±4700            | ±2880 | ±1440 | ±1440 |
| 150-250 | 150   | ±2300 | ±4100 | +4900<br>-7500   | ±3350 | ±1650 | ±1650 | 200   | ±2300 | ±4100 | +4900<br>-7500   | ±3350 | ±1650 | ±1650 |
| 150-315 | 150   | ±2500 | ±4300 | +5100<br>-7700   | ±3450 | ±1700 | ±1700 | 200   | ±2500 | ±4300 | +5100<br>-7700   | ±3450 | ±1700 | ±1700 |
| 150-400 | 150   | ±2550 | ±4350 | +5200<br>-7800   | ±3500 | ±1750 | ±1750 | 200   | ±2550 | ±4350 | +5200<br>-7800   | ±3500 | ±1750 | ±1750 |
| 150-500 | 150   | ±2600 | ±4400 | +5300<br>-7900   | ±3550 | ±1800 | ±1800 | 200   | ±2600 | ±4400 | +5300<br>-7900   | ±3550 | ±1800 | ±1800 |
| 200-250 | 200   | ±2700 | ±4900 | +6100<br>-9200   | ±4000 | ±2000 | ±2000 | 200   | ±2700 | ±4900 | +6100<br>-9200   | ±4000 | ±2000 | ±2000 |
| 200-315 | 200   | ±3200 | ±5400 | +6500<br>-9800   | ±4450 | ±2230 | ±2230 | 250   | ±3200 | ±5400 | +6500<br>-9800   | ±4450 | ±2230 | ±2230 |
| 200-400 | 200   | ±3300 | ±5500 | +6700<br>-10000  | ±4500 | ±2250 | ±2250 | 250   | ±3300 | ±5500 | +6700<br>-10000  | ±4500 | ±2250 | ±2250 |
| 200-500 | 200   | ±3400 | ±5600 | +7000<br>-10400  | ±4600 | ±2300 | ±2300 | 250   | ±3400 | ±5600 | +7000<br>-10400  | ±4600 | ±2300 | ±2300 |
| 250-315 | 250   | ±3800 | ±6500 | +7800<br>-11700  | ±4900 | ±2450 | ±2450 | 300   | ±3800 | ±6500 | +7800<br>-11700  | ±4900 | ±2450 | ±2450 |
| 250-400 | 250   | ±4000 | ±6700 | +8100<br>-12000  | ±5200 | ±2600 | ±2600 | 300   | ±4000 | ±6700 | +8100<br>-12000  | ±5200 | ±2600 | ±2600 |
| 250-500 | 250   | ±4100 | ±6800 | +8200<br>-12100  | ±5300 | ±2650 | ±2650 | 300   | ±4100 | ±6800 | +8200<br>-12100  | ±5300 | ±2650 | ±2650 |
| 300-400 | 300   | ±4750 | ±7900 | +9600<br>-14000  | ±6400 | ±3200 | ±3200 | 350   | ±4750 | ±7900 | +9600<br>-14000  | ±6400 | ±3200 | ±3200 |
| 300-500 | 300   | ±4900 | ±8100 | +10000<br>-14500 | ±6700 | ±3350 | ±3350 | 350   | ±4900 | ±8100 | +10000<br>-14500 | ±6700 | ±3350 | ±3350 |

# OPERATION INSTRUCTION

## 1. Brief Description

Before making description for the installation and operation of the CZ series product, especially for its safe nature, it is described briefly as follows:

1.1 It has to ensure that the operation working state point of the pump is coinciding with the data demanded by the contract or the parameters marked on the nameplate of the pump.

1.2 If the pump is able to produce harmful reflowing after stopping, it has to install check installation.

1.3 It is not allowed to start the pump, on which coupling cover has not been installed.

1.4 After the pump has been assembled, it has to have the lock washer clamped flatly to check the impeller nuts to prevent from loosening.

1.5 The suction and discharge (see sectional drawings 1-1), threaded holes and other open positions of the pump must flanges, be sealed and blocked up during transportation and storage.

1.6 It is not allowed to use the eyebolts on the pump and motor to lift pump single machine or the entire unit.

1.7 It is not allowed to discharge the medium transported at will to avoid corroding the base of the pump and polluting environment.

1.8 Before formal running, if there is no special condition, it is not allowed to disintegrate the pump voluntarily. (It does not include dismantling of motor and coupler for the purpose of installing pump base.)

## 2. Description of installation and Operation

The CZ Series Standard Chemical Process Pumps are centrifugal pumps of horizontal, single stage and single suction cantilever type. The product is tallied with the DIN24256/ISO2858 standard. It is suitable for transportation of medium being clean or

|          |                      |
|----------|----------------------|
| 010.00   | Casing               |
| 030.00   | Stuffing box housing |
| 030.01   | Stuffing box housing |
| * 040.00 | Impeller             |
| * 050.00 | Wear ring            |
| * 051.00 | Wear ring            |
| 090.00   | Shaft                |
| 090.01   | Shaft                |
| 100.00   | Bearing frame        |
| 130.00   | Plate                |
| 140.00   | Deflector            |
| 164.00   | Antifriction bearing |
| 164.01   | Antifriction bearing |
| 164.02   | Antifriction bearing |
| * 306.00 | Shaft sleeve         |
| 323.00   | Collar               |
| * 326.00 | Collar disc          |
| 335.00   | Gland insert         |
| 336.00   | Gland flange         |
| 340.00   | Bearing cover        |
| 340.01   | Bearing cover        |
| 367.00   | Lantern ring         |
| 391.00   | Foot                 |
| 430.00   | O-ring               |
| 430.01   | O-ring               |
| 431.00   | Sealing ring         |
| * 431.01 | Sealing ring         |
| * 432.00 | Gasket               |
| * 432.01 | Gasket               |
| * 440.00 | Packing ring         |
| * 461.00 | Cap nut              |
| 511.00   | Circlip              |
| 511.01   | Circlip              |
| 540.00   | Oil filling plug     |
| 552.00   | Constant level oiler |
|          | * Being spare parts  |

- A Impeller with back vanes, stuffing-box housing, uncooled
- B Impeller with back vanes  
Stuffing-box housing, cooled
- C Impeller with balancing bores  
Rear casing wear ring, Impeller dia 315mm.  
Stuffing-box housing cooled/uncooled

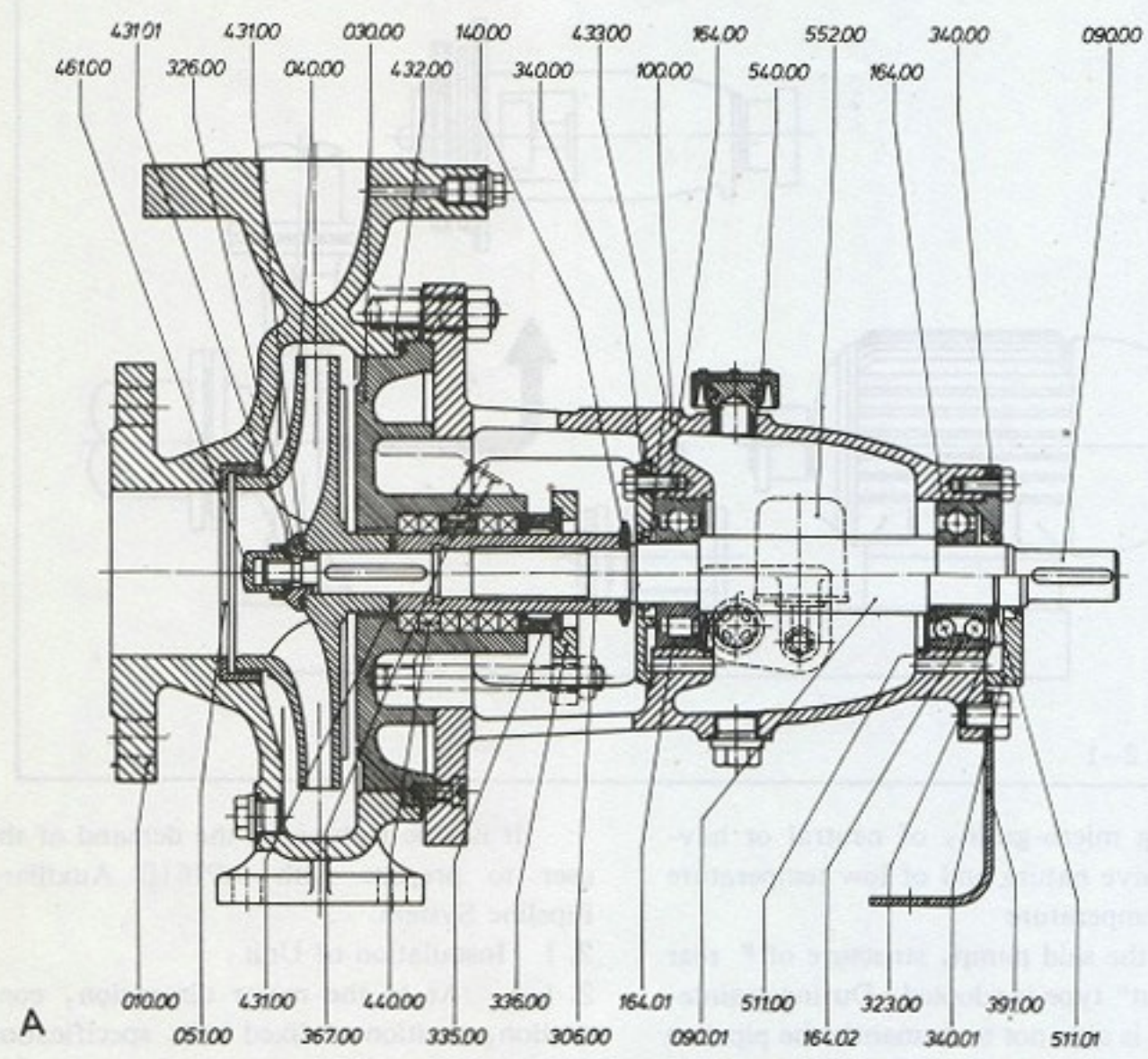

A

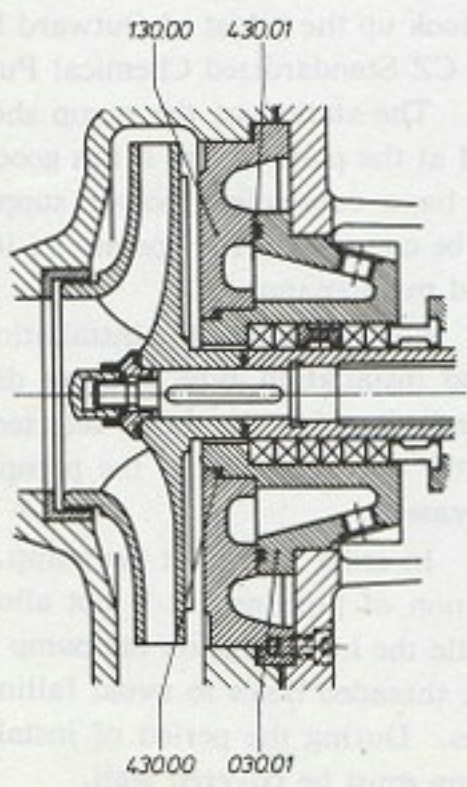

B

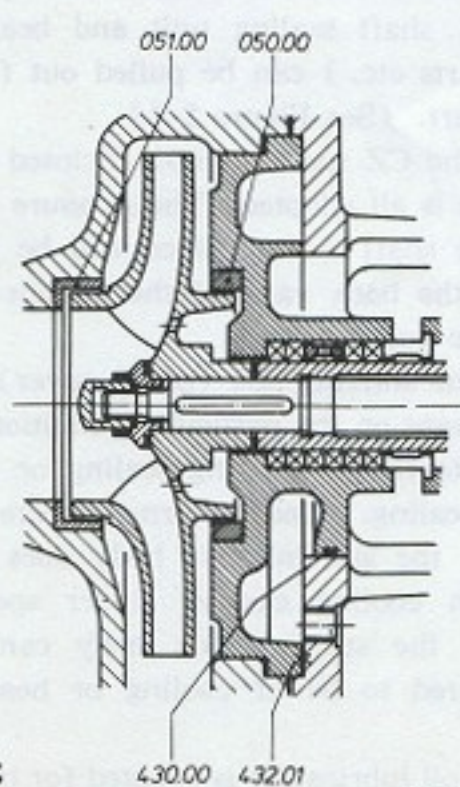

C

Fig 1-1



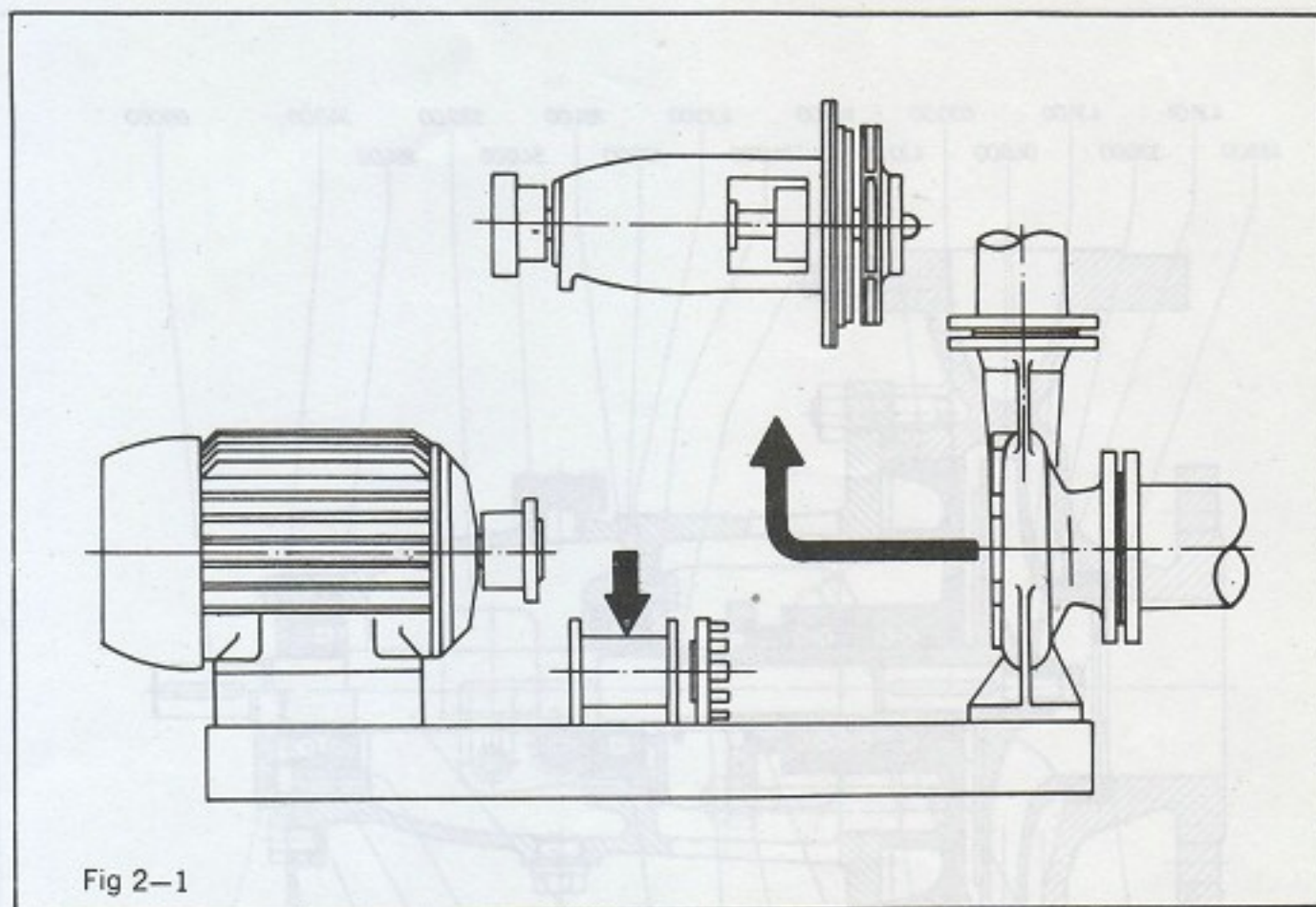

Fig 2-1

containing micro-grain, of neutral or having corrosive nature and of low temperature or high temperature

For the said pump, structure of " rear pulling out" type is adopted. During maintenance, it is able not to dismantle the pipeline even the motor and the entire rotor parts (impeller, shaft sealing unit and bearing support parts etc.) can be pulled out from the rear part. (See Figure 2-1)

For the CZ series pump, enclosed impeller type is all adopted. The pressure acting on the shaft sealing place will be balanced by the back vane of the impeller or the balance hole.

For the stuffing box (pump cover), it is able to base on the particular condition of operation to install stuffing sealing or mechanical sealing. Under normal operation condition, the stuffing box body does not carry with cooling cavity. under special condition, the stuffing box body can be manufactured to be of cooling or heating structure.

Thin oil lubrication is adopted for bearing.

It is able to base on the demand of the user to prepare with API610 Auxiliary Pipeline System.

## 2.1 Installation of Unit

2.1.1 As to the major dimension, connection, position of fixed bolt, specification of bolt and executing standard of flange, please look up the " List of Outward Dimension of CZ Standardized Chemical Pump".

2.1.2 The station of the pump should be situated at the place where it has good light, should have convenient power supply and should be convenient for operation, installation and maintenance.

2.1.3 For the pump, the installation position and installation type without displacement and vibration should be selected, otherwise the operation life of the pump would be decreased.

2.1.4 In order to protect the pump, before installation of pipeline, it is not allowed to dismantle the hole plugs on the pump flanges and the threaded holes to avoid falling in of sundries. During the period of installation, the pump must be covered well.

2.1.5 After completion of work on the

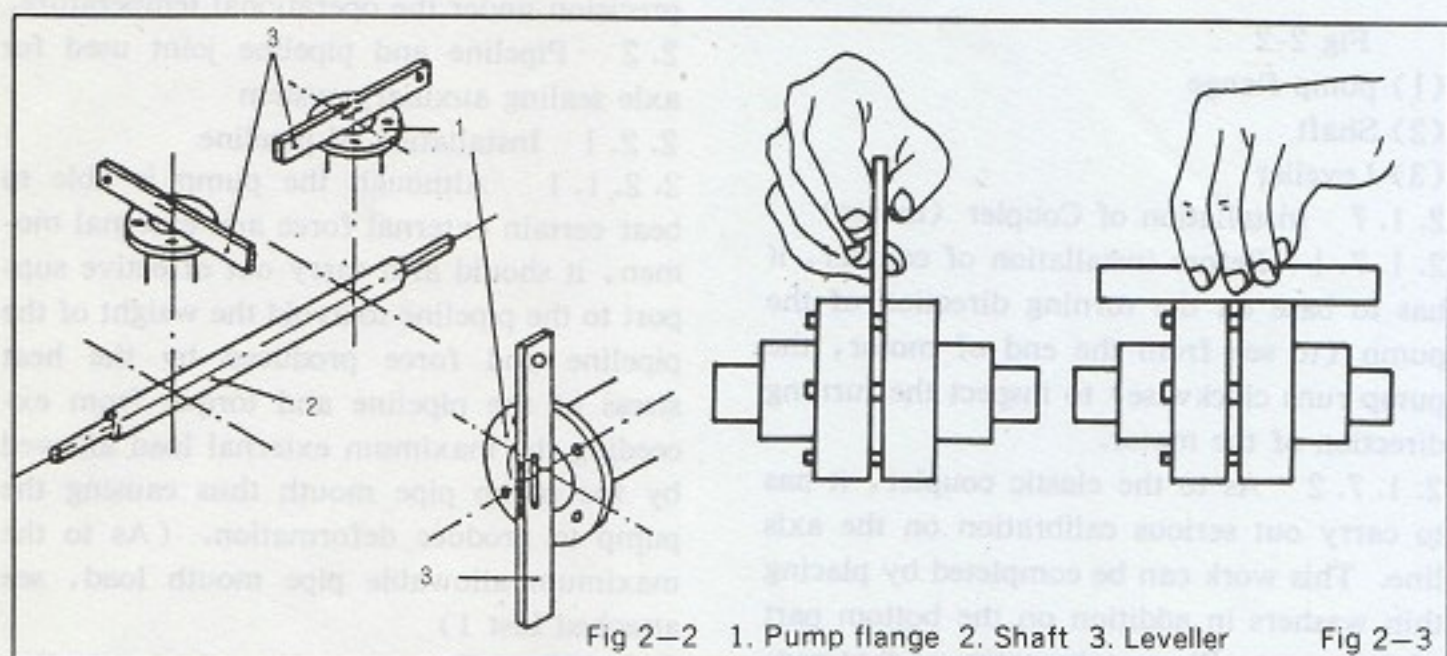

pump foundation and relative works for earth, the pump can be at the position to install only when the concrete has attained the effective age period.

#### 2. 1. 6 Installation of Pump Base

2. 1. 6. 1 Have the foundation bolts plugged into the bolt holes of the base and screw on washers and nuts. Have the pump unit placed on the foundation and use steel spacers of different thickness to place between the bottom surface of the base and the surface of the foundation after recondition to have the pump regulated to level. Between the base and foundation, certain clearance for grouting should be reserved. Use leveller to check the installation of pump unit according to the method shown in Figure 2-2. The maximum allowable deviation is 0. 1mm/m.

2. 1. 6. 2 Clear away the accumulated water and sundries in the pre-reserved holes of the foundation bolts and use concrete to grout the pre-reserved holes of the foundation bolts.

2. 1. 6. 3 After the concrete has been solidified, screw tightly the foundation bolts and nuts. Check the level again according to the level (shown in the Figure 2-2). If on the pump position there occurs change, it must be rectified again.

2. 1. 6. 4 After rectification, use concrete to grout the base and the entire space under the base should be grouted fully with concrete, that is that it needs to pour up to contact with the top plate, liquid collector and the whole part of reinforced bars. As to the welded base, it needs to grout up to the upper surface of the channel steel base foundation.

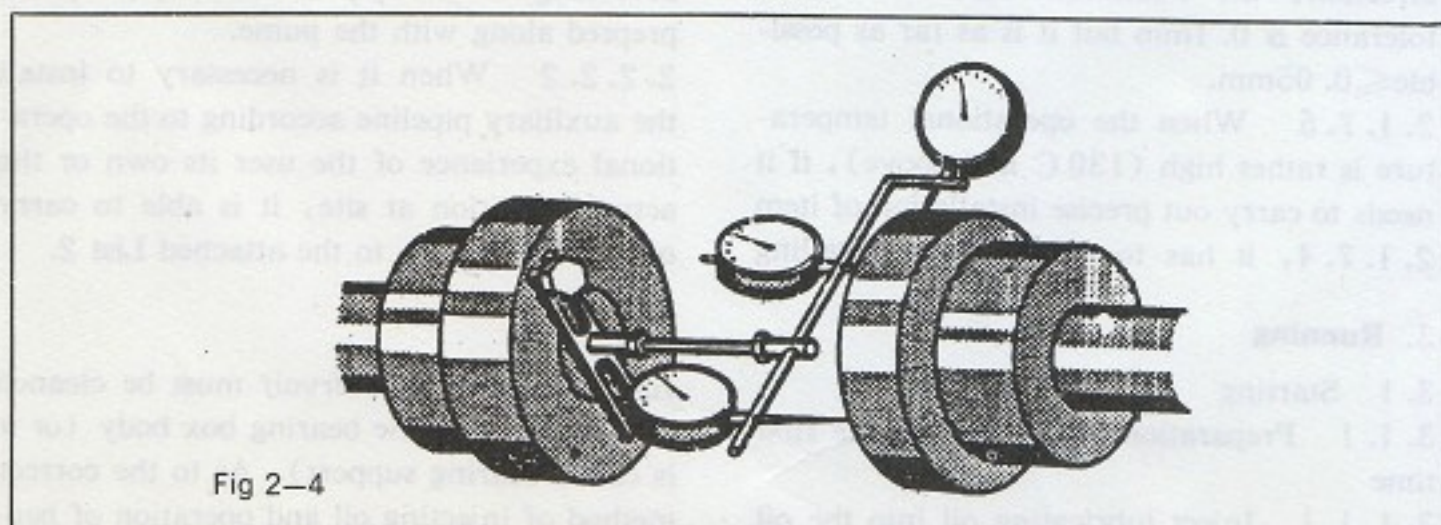

Fig 2-2

(1) pump flange

(2) Shaft

(3) Leveller

2.1.7 Installation of Coupler (motor)

2.1.7.1 Before installation of coupler, it has to base on the turning direction of the pump (to see from the end of motor, the pump runs clockwise) to inspect the turning direction of the motor.

2.1.7.2 As to the elastic coupler, it has to carry out serious calibration on the axis line. This work can be completed by placing thin washers in addition on the bottom part of the motor. Please take notice of that negligence during calibrating will cause destruction of coupler and damage of pump and motor bearing and enable the machine unit to produce harmful vibration and noise.

2.1.7.3 On the several direction points of the outer circumference of the coupler, it is separately to use straight edge and feeler gauge to carry out calibration on the radial direction and axial direction of the two half couplers (see Figure 2-3).

2.1.7.4 At the time when the revolving speed of the pump is greater than 3600 r/min. and the pump has lengthening coupler, it is necessary to carry out more precise installation. use dial gauge to carry out measuring on radial direction and axial direction as shown in Figure 2-4.

On the radial direction, the maximum allowable axial tolerance is 0.05mm but it is as far as possible  $\leq 0.03$ mm. On the radial direction, the maximum allowable radial tolerance is 0.1mm but it is as far as possible  $\leq 0.05$ mm.

2.1.7.5 When the operational temperature is rather high (130 C and above), if it needs to carry out precise installation of item 2.1.7.4, it has to calibrate its installing

### 3. Running

3.1 Starting

3.1.1 Preparation for starting at the first time

3.1.1.1 Inject lubricating oil into the oil

reservoir under the operational temperature.

2.2 Pipeline and pipeline joint used for axle sealing auxiliary system

2.2.1 Installation of pipeline

2.2.1.1 Although the pump is able to bear certain external force and external moment, it should also carry out effective support to the pipeline to avoid the weight of the pipeline and force produced by the heat stress of the pipeline and torque from exceeding the maximum external load allowed by the pump pipe mouth thus causing the pump to produce deformation. (As to the maximum allowable pipe mouth load, see attached List 1)

2.2.1.2 The centering of the sealing washers between the pump flange and the matching pipe flange should be ensured to avoid from sectional blocking of the pipeline.

2.2.1.3 Adopting irregular pipeline and elbow of rather small returning radius should be avoided, otherwise the resistance will be increased. Especially for the suction pipeline of the pump, rather great pipeline resistance will cause the pressure at the entrance of the pump to decrease thus affecting the suction capability of the pump and seriously it will cause the pump to produce air corrosion and unable to work normally.

2.2.2 Pipeline joint used for shaft sealing auxiliary system

2.2.2.1 When at the time of placing order, appointing auxiliary pipeline system according to API standard or GB5656-85 standard, it is able to carry out connection according to the pipeline and pipe joints preped along with the pume.

2.2.2.2 When it is necessary to install the auxiliary pipeline according to the operational experience of the user its own or the actual condition at site, it is able to carry out with reference to the attached List 2.

reservoir (the oil reservoir must be cleaned completely). of the bearing box body (or it is called bearing support). As to the correct method of injecting oil and operation of per-

manent position oil cup and selection of lubricating oil, see the lubricating part of section 4.3.

3.1.1.2 Inspect the coaxial degree of the coupler.

3.1.1.3 Inspect the axle sealing.

3.1.1.4 Inspect the turning direction of the motor.

3.1.1.5 Injection of Pump

3.1.1.5.1 The pump is at the situation of inverting injection

Open the valve of the suction pipeline and discharge air at the place of the exit pipe of the pump and the screw plug of the sealing box body. When there is no air bubble, close the air discharging plug.

3.1.1.5.2 The pump is at the situation of suction

There must be installed a bottom valve in the suction pipeline. Open the valve at the entrance pipeline and use transported medium to fill the pump to discharge air or use vacuum pump to draw and absorb.

3.1.2 Starting and Running of Pump

3.1.2.1 Open the valve in the pipeline of the auxiliary equipment.

3.1.2.2 Close the valve at the discharging pipeline, start the motor and then slowly open the valve at the discharging pipeline until the difference of pressure tallies with the value stipulated in the List of Data.

Note: (1) The difference of pressure is

## 4. Maintenance

### 4.1 Pump

4.1.1 During the period of running, inspect the stationary nature of running of the pump unit, observe whether there is the phenomenon of vibration or not and take notice of the abnormal running noise. Under the condition of not knowing the reason of producing noise and trouble, it firstly has to stop immediately, find out the reason and eliminate it.

4.1.2 Often inspect the connecting condition of the coupler. In order to avoid damage, if there occurs deformation, it should be

unable to be lower too much than the designed point and it is unable to have the phenomenon of fluctuation of pressure.

(2) The difference of pressure is equal to the gauge pressure value of suction of the pump minus the gauge pressure value of discharge of the pump.

### 3.2 Stopping

3.2.1 Close the valve of the discharging pipeline.

3.2.2 Close the motor and at the same time take notice of, observe and examine the condition of the rotor at the time of slowly stopping.

3.2.3 If the pump works under the condition of suction and moreover it is not planned to start again within a short time after stopping, at this time the valve in the suction in pipeline must be closed.

3.2.4 Close the valve in the pipeline of the auxiliary equipment (as to the cooling water, it will be closed after the pump has been cooled).

3.2.5 When there is the phenomenon of freezing or under the condition of stopping use for a long period of time, the liquid in the pump and in the auxiliary system must be emptied.

eliminated immediately.

4.1.3 Inspect the auxiliary system during the period of operation

4.1.3.1 Cooling; Inspect the condition of flowing and temperature.

4.1.3.2 Heating; Inspect the temperature and pressure.

4.1.3.3 Washing of Sealing; Inspect the pressure, temperature and the condition of flowing.

4.1.4 Under the condition of that there is establishment of stand-by pump, in order to ensure that the stand-by pump can be put in-

to operation immediately, trial running must be carried out periodically.

4.1.5 If the performance of the pump is descended not on account of the variation of the pipeline, system nor the variation of resistance of the pipeline, the decreasing of performance of the pump is possibly caused by wear of the internal parts of the pump,

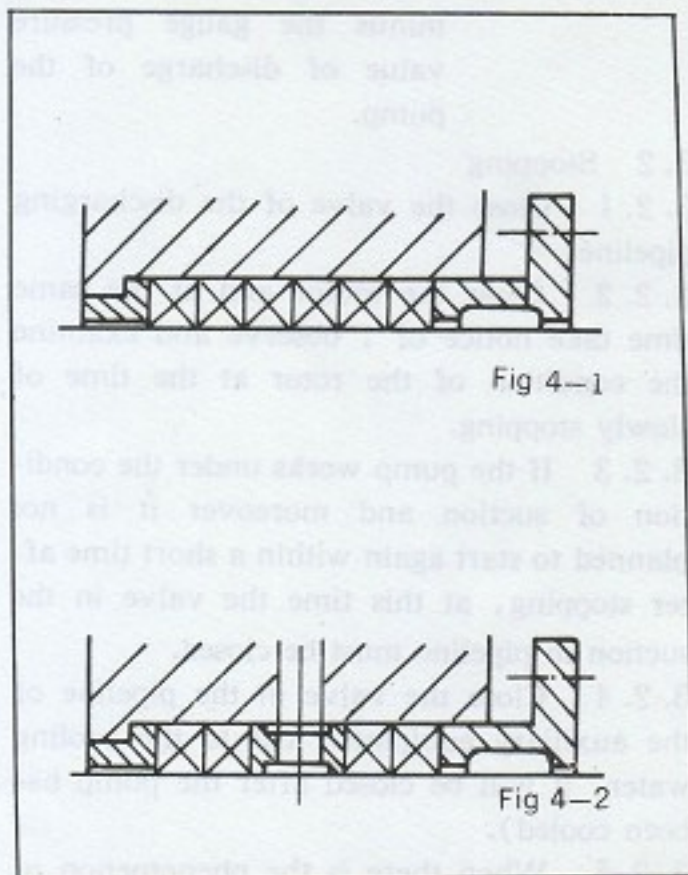

therefore the pump must be examined and repaired and the worn out parts must be replaced.

## 4.2 Shaft Sealing

### 4.2.1 Stuffing Sealing

#### 4.2.1.1 Conventional Structure (Figure 4-1)

Use stuffing ring to fill the entire stuffing cavity. The minimum overpressure at the place of axle sealing is 0.01-0.02MPa. The medium must have certain lubricating nature and moreover it is absolutely clean.

#### 4.2.1.2 Structure Carrying With Ring (Figure 4-2)

The water sealing ring, which is able to provide sealing liquid, is arranged in the middle position of the stuffing cavity. When the overpressure at the place of shaft sealing  $\leq 0.02\text{MPa}$  and moreover the lubricating nature of the liquid is inferior, sealing liquid

must be led in. The minimum pressure of the sealing liquid should be 0.1MPa greater than the pressure at the place of shaft sealing.

#### 4.2.1.3 Filling of Stuffing

As to the pump, which requires stuffing sealing, at the time of leaving the factory, its stuffing sealing has been filled well. If the pump after dispatching to site is unable to start within 12 weeks, it is necessary to replace with new stuffing before running.

Before filling stuffing, the shaft sleeve and the stuffing cavity should be cleaned and washed. The tolerance of the form and position of the shaft sleeve surface and surface roughness are needed to be inspected.

Demand:

(1) The radial out-of-true running of the external surface of the shaft sleeve must not be greater than 0.05mm.

(2) The coarseness of the external surface of the shaft sleeve must not be lower than 0.8.

Table 1

| The designed amount of flow of the pump $\text{m}^3/\text{h}$ | The amount of leaking of the shaft sealing $\text{ml}/\text{min}$ |
|---|---|
| $\leq 50$   | 15  |
| $> 50-100$  | 20  |
| $> 100-300$   | 30  |
| $> 300-1000$  | 40  |
| $> 1000$  | 60  |

When filling stuffing, it has to push the stuffing ring into the stuffing cavity one by one. At the place of seam of each stuffing ring, it should be staggered  $90^\circ$  and tightly against. As to the structure having water sealing ring, it has to take notice to have the water sealing ring aiming correctly at the entrance of sealing liquid.

Before rilling pump, it has to evenly press the stuffing tightly and it is not allowed to press to incline to one side. It is able to use checking and measuring instrument to inspect the distance between the gland flange and the stuffing cavity to enable them to ensure evenness and then screw the nuts tightly.

#### 4.2.1.4 Monitoring

The stuffing sealing should have certain amount of leaking to ensure good lubricating and cooling effect and steadiness of running. When the temperature of the leaked liquid does not exceed  $60^{\circ}\text{C}$ , the amount of leaking is from 1 litre/hour (about one drop per second) to 15 litres/hour (the liquid flow is about 2mm in diameter), it is able to be regarded as normal.

Under ordinary condition, it is able to control the amount of leaking according to the values in the Table 1:

When the pressure at the place of shaft sealing is smaller than 1MPa and the amount of leaking exceeds the stipulation mentioned above, it is able to evenly press tightly the stuffing, but do not enable the gland of the stuffing to incline nor to press too tightly. If the leaking is rather great after again pressing stuffing tightly and moreover the temperature of the leaked liquid exceeds the allowable value, it has to replace with new stuffing.

When the pressure at the place of shaft sealing is greater than 1MPa, under the condition of running of pump, again pressing tightly the stuffing will cause the shaft sealing to become ineffective. At this time, it has to replace with new stuffing.

Each time after filling with new stuffing, it has to go through a period of wearing-in and at the period of wearing-in it has to pay attention to inspect. After the period of wearing-in, the amount of leaking of the shaft sealing will be decreased.

#### 4.2.2 Mechanical Sealing

##### 4.2.2.1 Mechanical Sealing of Single Face

In order to ensure to have good sealing performance and steady running between the friction pairs of sealing (moving ring and static ring), there must be maintained a liquid film. Therefore, the transported medium must satisfy the following conditions;

(1) Good lubricating nature.

(2) The vapourized temperature is greater than the operational temperature.

(3) The medium near the friction pair does not contain admixture and grain.

The maintenance of the single face mechanical sealing chiefly includes monitoring of auxiliary system, amount of leaking and the temperature of cavity body of the mechanical sealing. Under ordinary condition, when the amount of leaking of single face mechanical sealing does not exceed 10 ml/h, it can be considered as normal. When the amount of leaking is rather great (greater than 50 ml/h), it can be concluded that the sealing was damaged and it should be examined and repaired immediately. At the time of examining and repairing, the sealing face worn out must be ground and polished again. As to the sealing ring which is unable to repair through grinding and polishing, it should be replaced.

At each time of dismantling and installing, the static sealing parts (such as O type ring etc.) must be replaced.

##### 4.2.2.2 Double End Face Mechanical Sealing

In the empty cavity formed by two end faces sealing, it has to lead the sealing liquid in. The pressure of the sealing liquid is needed to be 0.05-0.1 MPa higher than the pressure at the axle sealing at the transported medium end.

The maintenance of double faces mechanical sealing chiefly includes filling of sealing liquid, sealing and control of temperature of the auxiliary system.

When the consumption of sealing liquid is rather great or the amount of leaking of shaft sealing is rather great, it can be concluded that the sealing part was damaged and it has to examine and repair immediately. During examination and repair, it has to grind and polish the worn out sealing face again and as to the sealing ring which is unable to repair through grinding, it should be replaced. At each time of dismantling and installing sealing, the static sealing parts (such as O type ring etc.), they must be replaced with new ones.

#### 4.3 Lubricating

Table 2

| Temperature C |                 | ISO Viscosity Grade | Dynamic Viscosity mm <sup>2</sup> /s |      | Lowest Ignition Point C |
|---------------|-----------------|---------------------|--------------------------------------|------|-------------------------|
| Oil Reservoir | Bearing Support |                     | 40 C                                 | 50 C |                         |
| 40~65         | >50~75          | VG46                | 45                                   | 25   | 145                     |
| 65~75         | >75~85          | VG68                | 65                                   | 36   | 145                     |

#### 4.3.1 Lubricating oil

4.3.1.1 In order to ensure the bearing to have a rather long use life and to be able to run without troubles, good lubricating is the essential condition.

4.3.1.2 The lubricating oil must not contain any admixture, acid or resin etc.

4.3.1.3 Heating of bearing at the process of running and rising of environmental temperature take an important action on the variation of viscosity of the lubricating oil. The variation of viscosity directly affects its lubricating nature. In order to ensure the bearing to have a good lubricating condition, it is requested that the dynamic viscosity of the lubricating oil within the operational temperature limit of the bearing is not lower than 12mm<sup>2</sup>/s. It is able to select the lubricating oil according to the data provided by the Table 2.

4.3.1.4 After the first time of using of after examining and repairing of bearing, under the condition of using again, after the pump has run 10~15 hours, it should have

the oil discharged thoroughly and after cleaning the oil reservoir, inject in with new lubricating oil and then put it into normal running. During the normal operational period, it is able to replace the lubricating oil periodically according to stipulation of the Table 3.

Table 3

| Temperature C |                 | Period of Replacing (month) |
|---------------|-----------------|-----------------------------|
| Oil Reservoir | Bearing Support |                             |
| >40~65        | >50~75          | 12                          |
| >65~75        | >75~80          | 6                           |

4.3.1.5 Periodically inspect the rising of temperature of the oil reservoir or the bearing support.

#### 4.3.2 Filling of lubricating oil

4.3.2.1 Firstly, it has to fill the lubricating oil through the oil filling hole on the bearing support and the oil is filled up to that

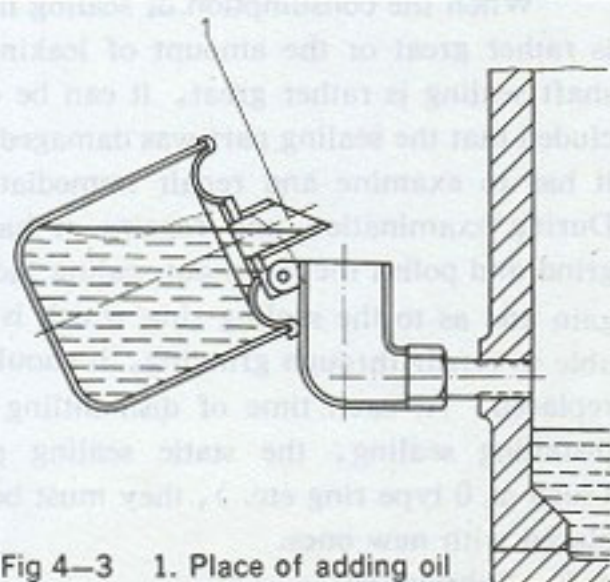

Fig 4-3 1. Place of adding oil

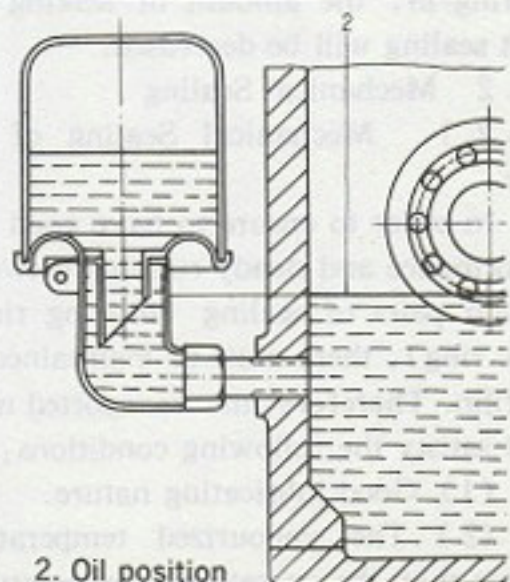

Fig 4-4 2. Oil position

the oil can be seen in the branch pipe of the permanent position oil cup or filled up to the indicating line on the oil showing window of the oil reservoir.

4.3.2.2 According to indication of the Figure 4—3, it is to add oil to the permanent position oil cup and then to have the oil cup to restore to the operational position (Figure 4—4). If the oil cup is on the operational position, the amount of oil in the oil cup is not enough  $2/3$  of the content of the oil

## 5. Examination and Repair

In order to avoid too long a period of stopping for examining and repairing, it has to purchase necessary spare articles and spare parts in advance. When buying spare parts from the manufacturer, it should provide the manufacturer with relative materials of type number of the pump, type of shaft sealing and the exact specification of spare parts and parts needed etc. in order to enable the manufacturer to search.

### 5.1 Dismantling

#### 5.1.1 Preparatory work

5.1.1.1 Close the in and out valves of the pump and pay attention to that it is not allowed to open at will to avoid causing accident.

5.1.1.2 Cut off the power supply of the motor to avoid from suddenly starting of the motor.

5.1.1.3 Discharge the liquid and lubricating oil in the pump thoroughly.

5.1.1.4 Dismantle the cover of the coupler and disassemble the coupler or dismantle the motor.

5.1.1.5 Dismantle all the instruments and the auxiliary pipeline.

#### 5.1.2 Dismantle unit

5.1.2.1 Dismantle the supporting foot bolts of the bearing support.

5.1.2.2 Dismantle the nuts of the stud bolt of the pump body.

5.1.2.3 Discharge the unit (carrying with bearing support of the shaft, pump cover, impeller etc. combined together). As to the

cup, it is able to repeat the process mentioned above up to that there is  $2/3$  of the oil content inside the oil cup.

4.3.2.3 After operation for a period of time, the oil position in the oil reservoir of the bearing support descends then repeat the process of 4.3.2.2 up to that it attains the requirement.

### Fig 4—3

(1) Place of adding oil (2) Oil position

rather big pump, it is able to have the aid of hoisting ring screws on the bearing support to carry out dismantling of unit.

#### 5.1.3 Dismantling of Shaft Sealing

5.1.3.1 Fix the pump shaft, prize open the lock washer and dismantle the nuts of the impeller.

5.1.3.2 Dismantle the impeller.

5.1.3.3 Dismantle the location screws of the pump cover and discharge the pump cover.

5.1.3.4 Dismantle the mechanical sealing gland or the tightening parts of the stuffing gland flange.

5.1.3.5 As to the mechanical sealing, it should have the shaft sleeve and the sealing turning parts to draw out together.

#### 5.1.4 Dismantling of shaft

5.1.4.1 Dismantle the shaft sleeve.

5.1.4.2 Dismantle the coupler at the end of pump.

5.1.4.3 Dismantle the dust proof pan (baffle disk).

5.1.4.4 Dismantle the front and rear bearing glands.

5.1.4.5 Use wooden hammer to knock the shaft out from the driving end.

### 5.2 Inspection of Parts

Inspect the wearing condition of the parts and as to the damaged parts, it should have them repaired again or replaced.

#### 5.2.1 Impeller and Turning Clearance

5.2.1.1 Inspect the condition of wearing and corroding of the impeller. As to those



Table 4

| Diameter at the place of clearance of wear ring of the impeller and pump casing (pump cover) (mm) |                 | <75 | 75~140 | >140~200 | >200~320 | >320~400 |
|---|-----------------|-----|--------|----------|----------|----------|
| Value of clearance of new parts (mm)  | Cast iron       | 0.3 | 0.4    | 0.5      | 0.6      | 0.7      |
|   | Stainless steel | 0.5 | 0.6    | 0.7      | 0.8      | 0.9      |
| Value of clearance of used parts (mm)   | Cast iron       | 0.9 | 1.2    | 1.5      | 1.8      | 2.0      |
|   | Stainless steel | 1.5 | 1.8    | 2.0      | 2.5      | 2.8      |

seriously damaged, they should be replaced.

5.2.1.2 Inspect the clearance between impeller and the pump body as well as the wear resistance rings (also called mouth rings). If the clearance exceeds the stipulation of the Table 4, it is able to carry out repairing or replacing with new parts according to the value in the Table 4.

## 5.2.2 Shaft Sealing Parts

### 5.2.2.1 Mechanical Sealing

On the wearing surfaces of the moving sealing and static sealing, there must be none of any scratch. If there is scratch, it is necessary to grind and polish again or to have it replaced.

### 5.2.2.2 Stuffing Sealing

5.2.2.2.1 As to the surface of shaft sleeve already worn out and having groove, if after it has been repaired again through processing and its diameter differs from the original diameter not enough 1mm, it is able to use. Under the condition of that the pressure of shaft sealing is greater than 1 MPa, it has to replace with new shaft sleeve.

5.2.2.2.2 Inspect the clearance between the stuffing gland bush and the shaft sleeve according to the Table 5.

Table 5

| Pressure of Shaft Sealing |                | ≤1 MPa | >1 MPa |
|---------------------------|----------------|--------|--------|
| Clearance mm              | Standard Value | 1mm    | 0.6mm  |
|                           | Maximum Value  | 2mm    | 1.2mm  |

### 5.2.3 Bearing

Wash the bearing and have it inspected and if there is damage, it has to replace it.

## 5.3 Assembling again

### 5.3.1 Preparatory work

5.3.1.1 Wash all the spare parts and parts of the pump.

5.3.1.2 Prepare lubricating dosage (such as lubricating oil and bivalent molybdenum etc.)

### 5.3.2 Assembly of shaft and Bearing

5.3.2.1 Have the bearing heated up to about 80°C (soaked in hot oil) and then fit it on the shaft.

5.3.2.2 Have the pump shaft carrying with bearings inserted into the bearing support from the end of coupler. After having the sealing face of the gland of bearing painted with epoxy resin glue, have it installed on the bearing support.

5.3.2.3 Install dust proof pan.

5.3.2.4 Install pump coupler.

### 5.3.3 Assembly of Entire Machine

Have the spare parts and parts after being washed assembled to become entire machine according to inverting order of dismantling.

## Attacheoldiagram

A Double mechanical seal

B Single mechanical seal

C Packed stuffingbox seal

| No  |     | size |
|-----|-----|------|
| 1   | 2   | 3    |
| 4   | 5   | 6    |
| 7   | 8   | 9    |
| 10  | 11  | 12   |
| 13  | 14  | 15   |
| 16  | 17  | 18   |
| 19  | 20  | 21   |
| 22  | 23  | 24   |
| 25  | 26  | 27   |
| 28  | 29  | 30   |
| 31  | 32  | 33   |
| 34  | 35  | 36   |
| 37  | 38  | 39   |
| 40  | 41  | 42   |
| 43  | 44  | 45   |
| 46  | 47  | 48   |
| 49  | 50  | 51   |
| 52  | 53  | 54   |
| 55  | 56  | 57   |
| 58  | 59  | 60   |
| 61  | 62  | 63   |
| 64  | 65  | 66   |
| 67  | 68  | 69   |
| 70  | 71  | 72   |
| 73  | 74  | 75   |
| 76  | 77  | 78   |
| 79  | 80  | 81   |
| 82  | 83  | 84   |
| 85  | 86  | 87   |
| 88  | 89  | 90   |
| 91  | 92  | 93   |
| 94  | 95  | 96   |
| 97  | 98  | 99   |
| 100 | 101 | 102  |

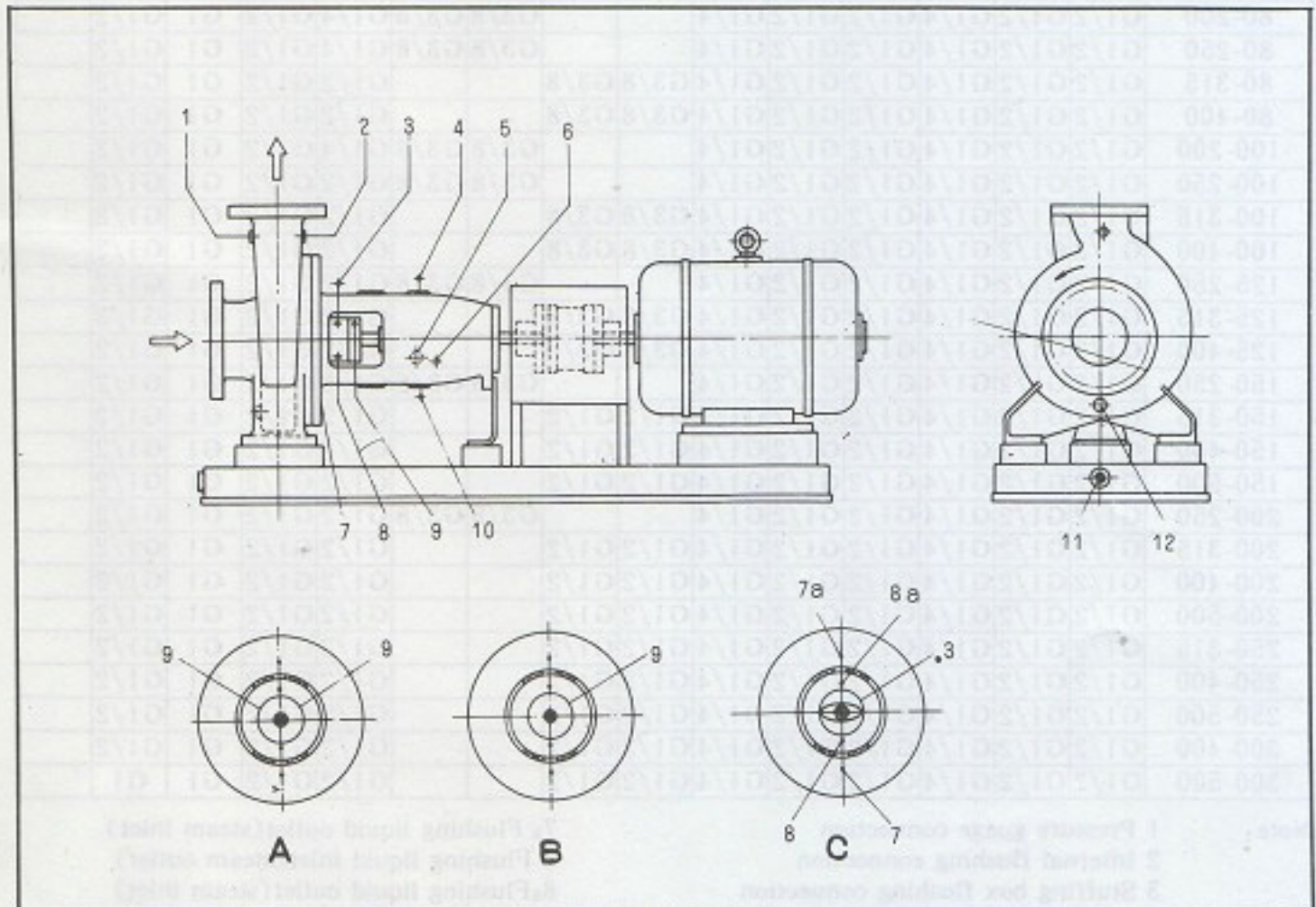

| connection<br>size | No   |      |      |      |      |      |      |                |      |                |      |      |    |      |    |
|--------------------|------|------|------|------|------|------|------|----------------|------|----------------|------|------|----|------|----|
|                    | 1    | 2    | 3    | 4    | 5    | 6    | 7    | 7 <sub>a</sub> | 8    | 8 <sub>a</sub> | 9    | 10   | 11 | 12   | 13 |
| 32-160             | G1/4 | G1/4 | G1/4 | G1/2 | G1/2 | G1/4 |      |                | G3/8 | G3/8           | G1/4 | G1/2 | G1 | G1/4 |    |
| 32-200             | G1/4 | G1/4 | G1/4 | G1/2 | G1/2 | G1/4 |      |                | G3/8 | G3/8           | G1/4 | G1/2 | G1 | G1/4 |    |
| 32-250             | G1/2 | G1/2 | G1/4 | G1/2 | G1/2 | G1/4 |      |                | G3/8 | G3/8           | G1/4 | G1/2 | G1 | G1/2 |    |
| 40-160             | G1/4 | G1/4 | G1/4 | G1/2 | G1/2 | G1/4 |      |                | G3/8 | G3/8           | G1/4 | G1/2 | G1 | G1/4 |    |
| 40-200             | G1/4 | G1/4 | G1/4 | G1/2 | G1/2 | G1/4 |      |                | G3/8 | G3/8           | G1/4 | G1/2 | G1 | G1/4 |    |
| 40-250             | G1/2 | G1/2 | G1/4 | G1/2 | G1/2 | G1/4 |      |                | G3/8 | G3/8           | G1/4 | G1/2 | G1 | G1/2 |    |
| 40-315             | G1/2 | G1/2 | G1/4 | G1/2 | G1/2 | G1/4 | G3/8 | G3/8           |      |                | G1/4 | G1/2 | G1 | G1/2 |    |
| 50-160             | G1/4 | G1/4 | G1/4 | G1/2 | G1/2 | G1/4 |      |                | G3/8 | G3/8           | G1/4 | G1/2 | G1 | G1/4 |    |
| 50-200             | G1/4 | G1/4 | G1/4 | G1/2 | G1/2 | G1/4 |      |                | G3/8 | G3/8           | G1/4 | G1/2 | G1 | G1/4 |    |
| 50-250             | G1/2 | G1/2 | G1/4 | G1/2 | G1/2 | G1/4 |      |                | G3/8 | G3/8           | G1/4 | G1/2 | G1 | G1/2 |    |
| 50-315             | G1/2 | G1/2 | G1/4 | G1/2 | G1/2 | G1/4 | G3/8 | G3/8           |      |                | G1/4 | G1/2 | G1 | G1/2 |    |
| 65-160             | G1/2 | G1/2 | G1/4 | G1/2 | G1/2 | G1/4 |      |                | G3/8 | G3/8           | G1/4 | G1/2 | G1 | G1/2 |    |
| 65-200             | G1/2 | G1/2 | G1/4 | G1/2 | G1/2 | G1/4 |      |                | G3/8 | G3/8           | G1/4 | G1/2 | G1 | G1/2 |    |
| 65-250             | G1/2 | G1/2 | G1/4 | G1/2 | G1/2 | G1/4 |      |                | G3/8 | G3/8           | G1/4 | G1/2 | G1 | G1/2 |    |
| 65-315             | G1/2 | G1/2 | G1/4 | G1/2 | G1/2 | G1/4 |      |                | G3/8 | G3/8           | G1/2 | G1/2 | G1 | G1/2 |    |
| 80-160             | G1/2 | G1/2 | G1/4 | G1/2 | G1/2 | G1/4 |      |                | G3/8 | G3/8           | G1/4 | G1/2 | G1 | G1/2 |    |
| 80-200             | G1/2 | G1/2 | G1/4 | G1/2 | G1/2 | G1/4 |      |                | G3/8 | G3/8           | G1/4 | G1/2 | G1 | G1/2 |    |
| 80-250             | G1/2 | G1/2 | G1/4 | G1/2 | G1/2 | G1/4 |      |                | G3/8 | G3/8           | G1/4 | G1/2 | G1 | G1/2 |    |
| 80-315             | G1/2 | G1/2 | G1/4 | G1/2 | G1/2 | G1/4 | G3/8 | G3/8           |      |                | G1/2 | G1/2 | G1 | G1/2 |    |
| 80-400             | G1/2 | G1/2 | G1/4 | G1/2 | G1/2 | G1/4 | G3/8 | G3/8           |      |                | G1/2 | G1/2 | G1 | G1/2 |    |
| 100-200            | G1/2 | G1/2 | G1/4 | G1/2 | G1/2 | G1/4 |      |                | G3/8 | G3/8           | G1/4 | G1/2 | G1 | G1/2 |    |
| 100-250            | G1/2 | G1/2 | G1/4 | G1/2 | G1/2 | G1/4 |      |                | G3/8 | G3/8           | G1/2 | G1/2 | G1 | G1/2 |    |
| 100-315            | G1/2 | G1/2 | G1/4 | G1/2 | G1/2 | G1/4 | G3/8 | G3/8           |      |                | G1/2 | G1/2 | G1 | G1/2 |    |
| 100-400            | G1/2 | G1/2 | G1/4 | G1/2 | G1/2 | G1/4 | G3/8 | G3/8           |      |                | G1/2 | G1/2 | G1 | G1/2 |    |
| 125-250            | G1/2 | G1/2 | G1/4 | G1/2 | G1/2 | G1/4 |      |                | G3/8 | G3/8           | G1/2 | G1/2 | G1 | G1/2 |    |
| 125-315            | G1/2 | G1/2 | G1/4 | G1/2 | G1/2 | G1/4 | G3/8 | G3/8           |      |                | G1/2 | G1/2 | G1 | G1/2 |    |
| 125-400            | G1/2 | G1/2 | G1/4 | G1/2 | G1/2 | G1/4 | G3/8 | G3/8           |      |                | G1/2 | G1/2 | G1 | G1/2 |    |
| 150-250            | G1/2 | G1/2 | G1/4 | G1/2 | G1/2 | G1/4 |      |                | G3/8 | G3/8           | G1/2 | G1/2 | G1 | G1/2 |    |
| 150-315            | G1/2 | G1/2 | G1/4 | G1/2 | G1/2 | G1/4 | G1/2 | G1/2           |      |                | G1/2 | G1/2 | G1 | G1/2 |    |
| 150-400            | G1/2 | G1/2 | G1/4 | G1/2 | G1/2 | G1/4 | G1/2 | G1/2           |      |                | G1/2 | G1/2 | G1 | G1/2 |    |
| 150-500            | G1/2 | G1/2 | G1/4 | G1/2 | G1/2 | G1/4 | G1/2 | G1/2           |      |                | G1/2 | G1/2 | G1 | G1/2 |    |
| 200-250            | G1/2 | G1/2 | G1/4 | G1/2 | G1/2 | G1/4 |      |                | G3/8 | G3/8           | G1/2 | G1/2 | G1 | G1/2 |    |
| 200-315            | G1/2 | G1/2 | G1/4 | G1/2 | G1/2 | G1/4 | G1/2 | G1/2           |      |                | G1/2 | G1/2 | G1 | G1/2 |    |
| 200-400            | G1/2 | G1/2 | G1/4 | G1/2 | G1/2 | G1/4 | G1/2 | G1/2           |      |                | G1/2 | G1/2 | G1 | G1/2 |    |
| 200-500            | G1/2 | G1/2 | G1/4 | G1/2 | G1/2 | G1/4 | G1/2 | G1/2           |      |                | G1/2 | G1/2 | G1 | G1/2 |    |
| 250-315            | G1/2 | G1/2 | G1/4 | G1/2 | G1/2 | G1/4 | G1/2 | G1/2           |      |                | G1/2 | G1/2 | G1 | G1/2 |    |
| 250-400            | G1/2 | G1/2 | G1/4 | G1/2 | G1/2 | G1/4 | G1/2 | G1/2           |      |                | G1/2 | G1/2 | G1 | G1/2 |    |
| 250-500            | G1/2 | G1/2 | G1/4 | G1/2 | G1/2 | G1/4 | G1/2 | G1/2           |      |                | G1/2 | G1/2 | G1 | G1/2 |    |
| 300-400            | G1/2 | G1/2 | G1/4 | G1/2 | G1/2 | G1/4 | G1/2 | G1/2           |      |                | G1/2 | G1/2 | G1 | G1/2 |    |
| 300-500            | G1/2 | G1/2 | G1/4 | G1/2 | G1/2 | G1/4 | G1/2 | G1/2           |      |                | G1/2 | G1/2 | G1 | G1   |    |

Note:

- 1 Pressure gauge connection
- 2 Internal flushing connection
- 3 Stuffing box flushing connection
- 4 Filler plug
- 5 Sight glass connection
- 6 Constant level oiler connection
- 7 Flushing liquid inlet (steam outlet)

- 7<sub>a</sub> Flushing liquid outlet (steam inlet)
- 8 Flushing liquid inlet (steam outlet)
- 8<sub>a</sub> Flushing liquid outlet (steam inlet)
- 9 Mechanical seal pipe connection
- 10 Bearing bracket drain
- 11 Baseplate drain
- 12 Casing drain

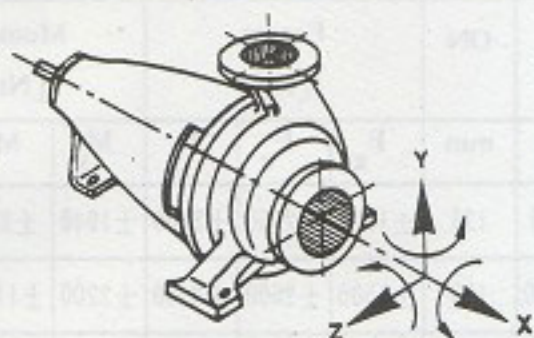

| size   | Discharge branch |                |                |                |                 |                |                | Discharge branch |                |                |                |                 |                |                |
|--------|------------------|----------------|----------------|----------------|-----------------|----------------|----------------|------------------|----------------|----------------|----------------|-----------------|----------------|----------------|
|        | ON<br>mm         | Forces<br>[N]  |                |                | Moments<br>[Nm] |                |                | ON<br>mm         | Forces<br>[N]  |                |                | Moments<br>[Nm] |                |                |
|        |                  | F <sub>x</sub> | F <sub>z</sub> | F <sub>y</sub> | M <sub>x</sub>  | M <sub>z</sub> | M <sub>y</sub> |                  | F <sub>x</sub> | F <sub>z</sub> | F <sub>y</sub> | M <sub>x</sub>  | M <sub>z</sub> | M <sub>y</sub> |
| 32-160 | 32               | ±800           | ±1350          | +1750<br>-2600 | ±980            | ±490           | ±490           | 50               | ±800           | ±1350          | ±1750          | ±980            | ±490           | ±490           |
| 32-200 | 32               | ±850           | ±1420          | +1820<br>-2750 | ±1020           | ±510           | ±510           | 50               | ±850           | ±1420          | ±1820          | 1020            | 510            | 510            |
| 32-250 | 32               | ±900           | ±1500          | +1900<br>-2900 | ±1040           | ±520           | 520            | 50               | ±900           | ±1500          | ±1900          | ±1040           | ±520           | ±520           |
| 40-160 | 40               | ±850           | ±1400          | +1800<br>-2700 | ±1000           | ±500           | ±500           | 65               | ±850           | ±1400          | ±1800          | ±1000           | ±500           | ±500           |
| 40-200 | 40               | ±900           | ±1520          | +1920<br>-2900 | ±1020           | ±510           | ±510           | 65               | ±900           | ±1520          | ±1920          | ±1020           | ±510           | ±510           |
| 40-250 | 40               | ±950           | ±1600          | +1950<br>-2940 | ±1040           | ±520           | ±520           | 65               | ±950           | ±1600          | ±1950          | ±1040           | ±520           | ±520           |
| 40-315 | 40               | ±980           | ±1650          | +2000<br>-3000 | ±1080           | ±540           | ±540           | 65               | ±980           | ±1650          | ±2000          | ±1080           | ±540           | ±540           |
| 50-160 | 50               | ±900           | ±1700          | +2100<br>-3150 | ±1280           | ±640           | ±640           | 80               | ±900           | ±1700          | ±2100          | ±1280           | ±640           | ±640           |
| 50-200 | 50               | ±950           | ±1750          | +2150<br>-3220 | ±1300           | ±650           | ±650           | 80               | ±950           | ±1750          | ±2150          | ±1300           | ±650           | ±650           |
| 50-250 | 50               | ±1000          | ±1850          | +2250<br>-3380 | ±1320           | ±660           | ±660           | 80               | ±1000          | ±1850          | ±2250          | ±1320           | ±660           | ±660           |
| 50-315 | 50               | ±1100          | ±1950          | +2400<br>-3600 | ±1360           | ±680           | ±680           | 80               | ±1100          | ±1950          | ±2400          | ±1360           | ±680           | ±680           |
| 65-160 | 65               | ±1200          | ±2150          | +2700<br>-4000 | ±1660           | ±830           | ±830           | 100              | ±1200          | ±2150          | ±2700          | ±1660           | ±830           | ±830           |
| 65-200 | 65               | ±1300          | ±2200          | +2800<br>-4200 | ±1680           | ±840           | ±840           | 100              | ±1300          | ±2200          | ±2800          | ±1680           | ±840           | ±840           |
| 65-250 | 65               | ±1400          | ±2250          | +3000<br>-4350 | ±1700           | ±850           | ±850           | 100              | ±1400          | ±2250          | ±2900          | ±1700           | ±850           | ±850           |
| 65-315 | 65               | ±1450          | ±2350          | +3000<br>-4500 | ±1720           | ±860           | ±860           | 100              | ±1450          | ±2350          | ±3000          | ±1720           | ±860           | ±860           |
| 80-160 | 80               | ±1250          | ±2350          | +3000<br>-4500 | ±1850           | ±910           | ±910           | 125              | ±1250          | ±2350          | ±3000          | ±1850           | ±910           | ±910           |
| 80-200 | 80               | ±1300          | 2400           | +3100<br>-4650 | ±1840           | ±920           | ±920           | 125              | ±1300          | ±2400          | ±3100          | ±1840           | ±920           | ±920           |
| 80-250 | 80               | ±1400          | ±2600          | +3200<br>-4850 | ±1900           | ±950           | ±950           | 125              | ±1400          | ±2600          | ±3200          | ±1900           | ±950           | ±950           |
| 80-315 | 80               | ±1450          | ±2700          | +3250<br>-4850 | ±1920           | ±960           | ±960           | 125              | ±1450          | ±2700          | ±3250          | ±1920           | ±960           | ±960           |

| size    | Discharge branch |                |                |                  |                 |                |                | Discharge branch |                |                |                  |                 |                |                |
|---------|------------------|----------------|----------------|------------------|-----------------|----------------|----------------|------------------|----------------|----------------|------------------|-----------------|----------------|----------------|
|         | ON               | Forces<br>[N]  |                |                  | Moments<br>[Nm] |                |                | ON               | Forces<br>[N]  |                |                  | Moments<br>[Nm] |                |                |
|         | mm               | F <sub>x</sub> | F <sub>z</sub> | F <sub>y</sub>   | M <sub>x</sub>  | M <sub>z</sub> | M <sub>y</sub> | mm               | F <sub>x</sub> | F <sub>z</sub> | F <sub>y</sub>   | M <sub>x</sub>  | M <sub>z</sub> | M <sub>y</sub> |
| 80-400  | 80               | ±1500          | ±2750          | +3300<br>-4950   | ±1940           | ±970           | ±970           | 125              | ±1500          | ±2750          | ±3300            | ±1940           | ±970           | ±970           |
| 100-200 | 100              | ±1500          | ±2600          | +3400<br>-4750   | ±2200           | ±1100          | ±1100          | 125              | ±1500          | ±2600          | ±3400            | ±2200           | ±1100          | ±1100          |
| 100-250 | 100              | ±1650          | ±2700          | +3500<br>-4900   | ±2240           | ±1120          | ±1120          | 125              | ±1650          | ±2700          | ±3500            | ±2240           | ±1120          | ±1120          |
| 100-315 | 100              | ±1700          | ±2750          | +3600<br>-5050   | ±2260           | ±1130          | ±1130          | 125              | ±1700          | ±2750          | ±3600            | ±2260           | ±1130          | ±1130          |
| 100-400 | 100              | ±1800          | ±2850          | +3700<br>-5180   | ±2280           | ±1140          | ±1140          | 125              | ±1800          | ±2850          | ±3700            | ±2280           | ±1140          | ±1140          |
| 125-250 | 125              | ±1800          | ±3500          | +4500<br>-6200   | ±2800           | ±1400          | ±1400          | 150              | ±1800          | ±3500          | ±4500            | ±2800           | ±1400          | ±1400          |
| 125-315 | 125              | ±2000          | ±3600          | +4650<br>-6400   | ±2860           | ±1430          | ±1430          | 150              | ±2000          | ±3600          | ±4650            | ±2860           | ±1430          | ±1430          |
| 125-400 | 125              | ±2100          | ±3650          | +4700<br>-6500   | ±2880           | ±1440          | ±1440          | 150              | ±2100          | ±3650          | ±4700            | ±2880           | ±1440          | ±1440          |
| 150-250 | 150              | ±2300          | ±4100          | +4900<br>-7500   | ±3350           | ±1650          | ±1650          | 200              | ±2300          | ±4100          | +4900<br>-7500   | ±3350           | ±1650          | ±1650          |
| 150-315 | 150              | ±2500          | ±4300          | +5100<br>-7700   | ±3450           | ±1700          | ±1700          | 200              | ±2500          | ±4300          | +5100<br>-7700   | ±3450           | ±1700          | ±1700          |
| 150-400 | 150              | ±2550          | ±4350          | +5200<br>-7800   | ±3500           | ±1750          | ±1750          | 200              | ±2550          | ±4350          | +5200<br>-7800   | ±3500           | ±1750          | ±1750          |
| 150-500 | 150              | ±2600          | ±4400          | +5300<br>-7900   | ±3550           | ±1800          | ±1800          | 200              | ±2600          | ±4400          | +5300<br>-7900   | ±3550           | ±1800          | ±1800          |
| 200-250 | 200              | ±2700          | ±4900          | +6100<br>-9200   | ±4000           | ±2000          | ±2000          | 200              | ±2700          | ±4900          | +6100<br>-9200   | ±4000           | ±2000          | ±2000          |
| 200-315 | 200              | ±3200          | ±5400          | +6500<br>-9800   | ±4450           | ±2230          | ±2230          | 250              | ±3200          | ±5400          | +6500<br>-9800   | ±4450           | ±2230          | ±2230          |
| 200-400 | 200              | ±3300          | ±5500          | +6700<br>-10000  | ±4500           | ±2250          | ±2250          | 250              | ±3300          | ±5500          | +6700<br>-10000  | ±4500           | ±2250          | ±2250          |
| 200-500 | 200              | ±3400          | ±5600          | +7000<br>-10400  | ±4600           | ±2300          | ±2300          | 250              | ±3400          | ±5600          | +7000<br>-10400  | ±4600           | ±2300          | ±2300          |
| 250-315 | 250              | ±3800          | ±6500          | +7800<br>-11700  | ±4900           | ±2450          | ±2450          | 300              | ±3800          | ±6500          | +7800<br>-11700  | ±4900           | ±2450          | ±2450          |
| 250-400 | 250              | ±4000          | ±6700          | +8100<br>-12000  | ±5200           | ±2600          | ±2600          | 300              | ±4000          | ±6700          | +8100<br>-12000  | ±5200           | ±2600          | ±2600          |
| 250-500 | 250              | ±4100          | ±6800          | +8200<br>-12100  | ±5300           | ±2650          | ±2650          | 300              | ±4100          | ±6800          | +8200<br>-12100  | ±5300           | ±2650          | ±2650          |
| 300-400 | 300              | ±4750          | ±7900          | +9600<br>-14000  | ±6400           | ±3200          | ±3200          | 350              | ±4750          | ±7900          | +9600<br>-14000  | ±6400           | ±3200          | ±3200          |
| 300-500 | 300              | ±4900          | ±8100          | +10000<br>-14500 | ±6700           | ±3350          | ±3350          | 350              | ±4900          | ±8100          | +10000<br>-14500 | ±6700           | ±3350          | ±3350          |